

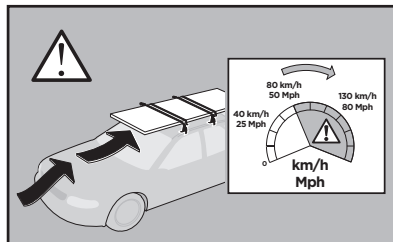

Thule Rapid System Kit 1783

> Instructions

CHEVROLET Colorado, 4-dr Crew Cab, 15-
CHEVROLET S10, 4-dr Double Cab, 12-
GMC Canyon, 4-dr Crew Cab, 15-
HOLDEN Colorado, 4-dr Double Cab, 12-
ISUZU D-Max, 4-dr Crew Cab, 12-

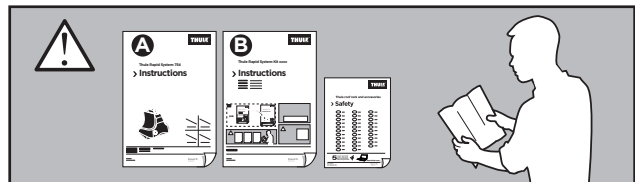
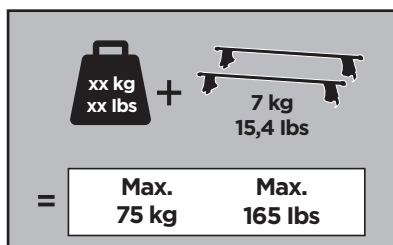
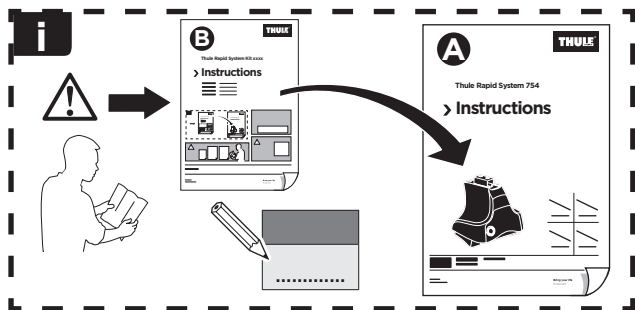
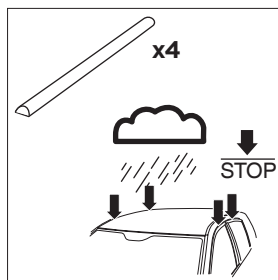

ISO 11154-E

141783
C.20160707
519-1783-02

Bring your life
thule.com



390 x2

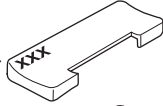

391 x1

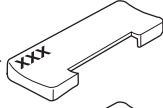

392 x1

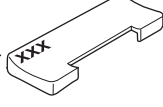

1234 x4

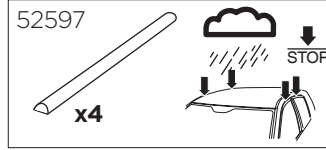

x1



x1

1

	X (scale)	X (mm)	X (inch)
CHEVROLET Colorado , 4-dr Crew Cab, 15-	38	1031	40 ⁵ / ₈
CHEVROLET S10 , 4-dr Double Cab, 12-	38	1031	40 ⁵ / ₈
GMC Canyon , 4-dr Crew Cab, 15-	38	1031	40 ⁵ / ₈
HOLDEN Colorado , 4-dr Double Cab, 12-	38	1031	40 ⁵ / ₈
ISUZU D-Max , 4-dr Crew Cab, 12-	38	1031	40 ⁵ / ₈

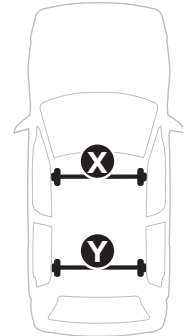
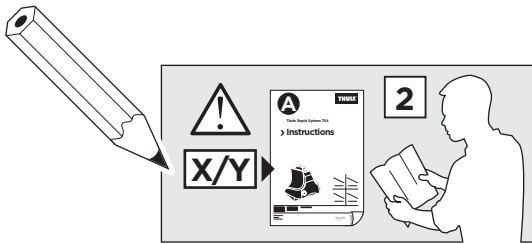

	Y (scale)	Y (mm)	Y (inch)
CHEVROLET Colorado , 4-dr Crew Cab, 15-	35.5	1006	39 ⁵ / ₈
CHEVROLET S10 , 4-dr Double Cab, 12-	35.5	1006	39 ⁵ / ₈
GMC Canyon , 4-dr Crew Cab, 15-	35.5	1006	39 ⁵ / ₈
HOLDEN Colorado , 4-dr Double Cab, 12-	35.5	1006	39 ⁵ / ₈
ISUZU D-Max , 4-dr Crew Cab, 12-	35.5	1006	39 ⁵ / ₈

2

CHEVROLET Colorado, 4-dr Crew Cab, 15-
CHEVROLET S10, 4-dr Double Cab, 12-
GMC Canyon, 4-dr Crew Cab, 15-
HOLDEN Colorado, 4-dr Double Cab, 12-
ISUZU D-Max, 4-dr Crew Cab, 12-

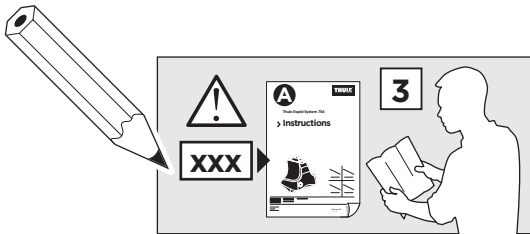
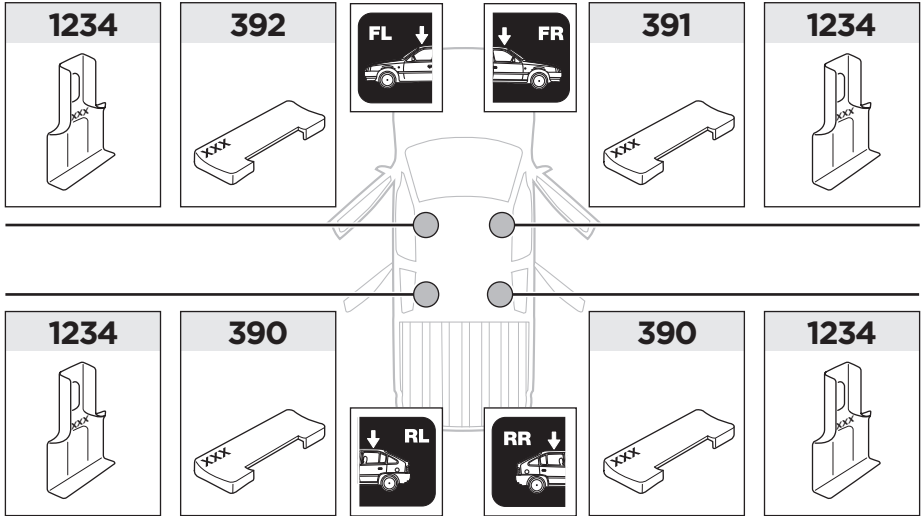

3

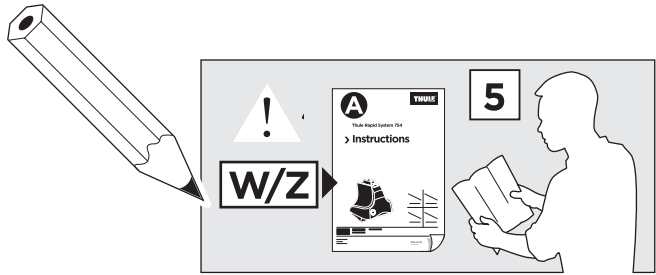

	W (mm)	Z (mm)	W (inch)	Z (inch)
CHEVROLET Colorado , 4-dr Crew Cab, 15-	250	700	9 7/8	27 1/4
CHEVROLET S10 , 4-dr Double Cab, 12-	250	700	9 7/8	27 1/4
GMC Canyon , 4-dr Crew Cab, 15-	250	700	9 7/8	27 1/4
HOLDEN Colorado , 4-dr Double Cab, 12-	250	700	9 7/8	27 1/4
ISUZU D-Max , 4-dr Crew Cab, 12-	250	700	9 7/8	27 1/4

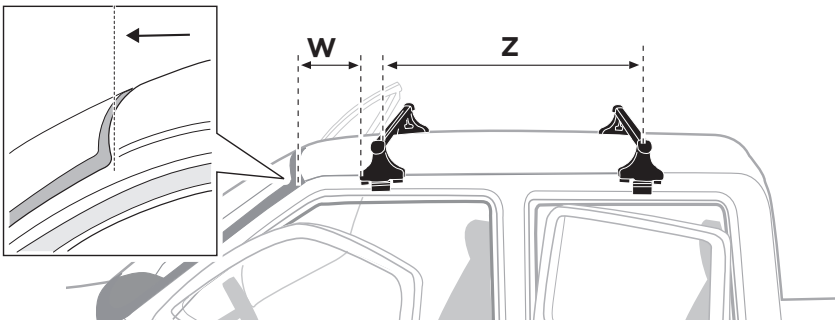

4

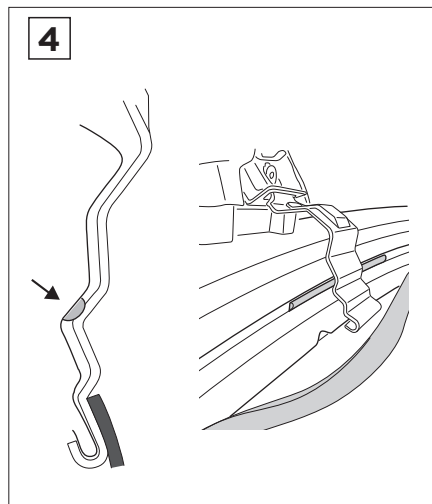
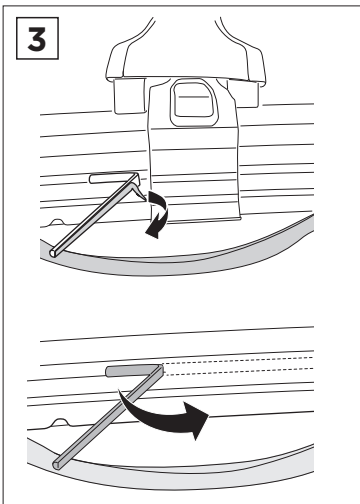
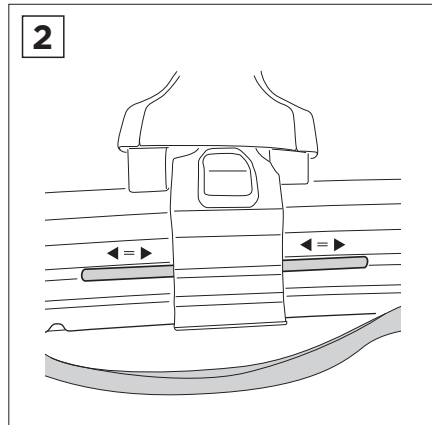
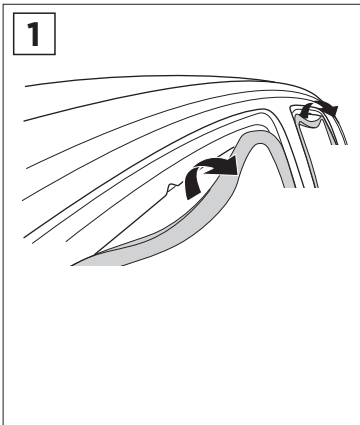
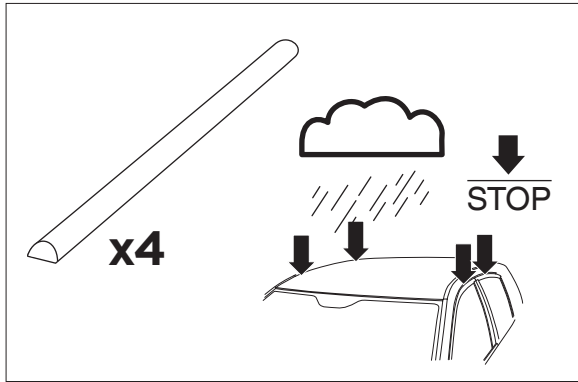

5

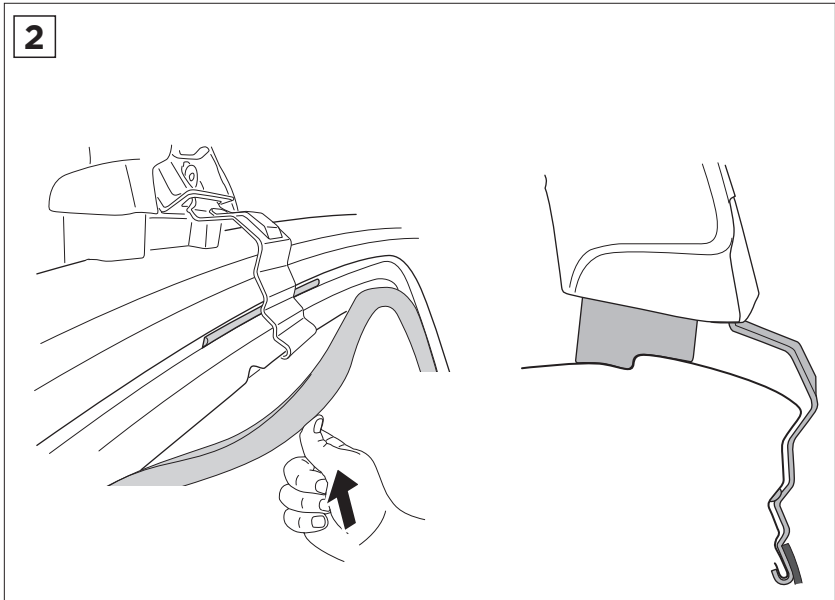
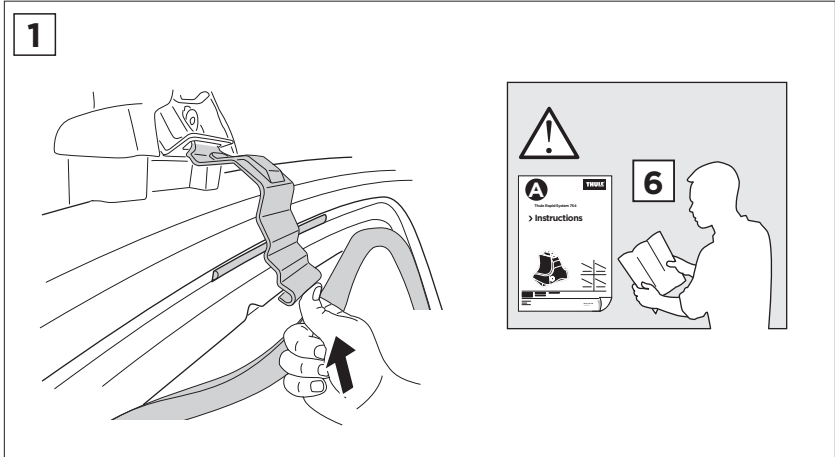

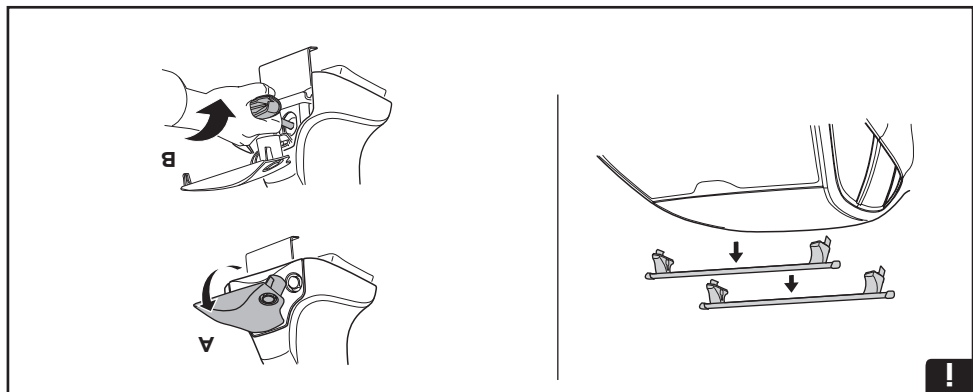
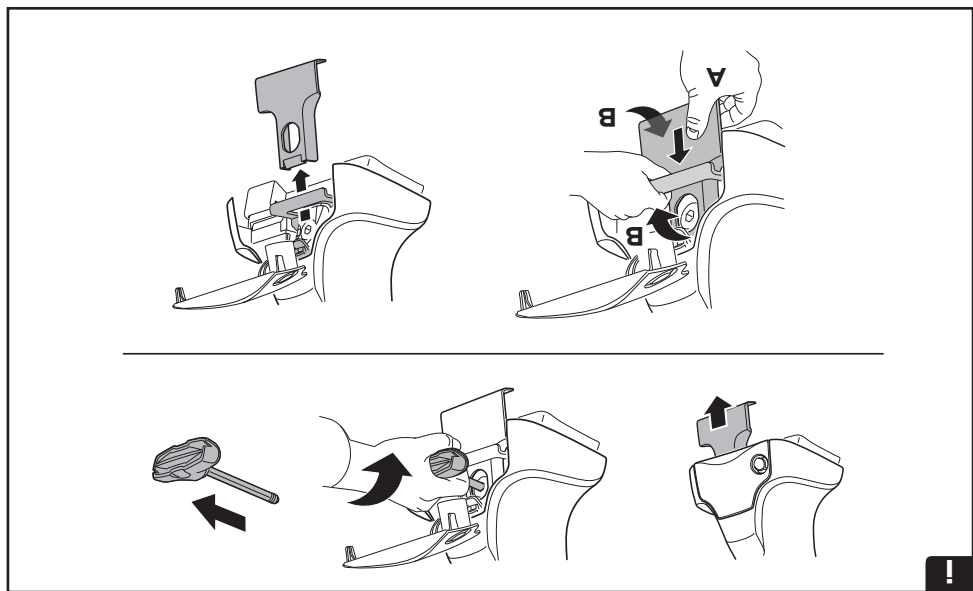

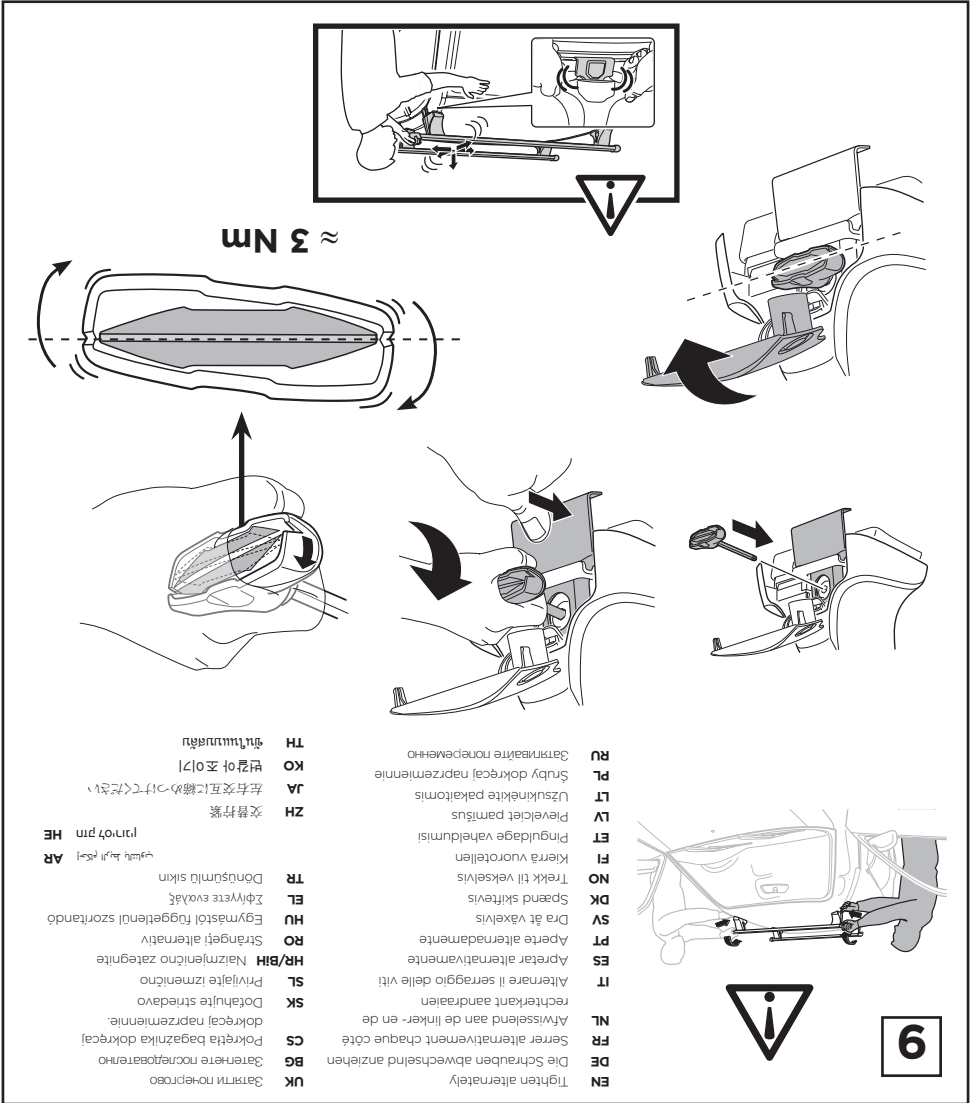
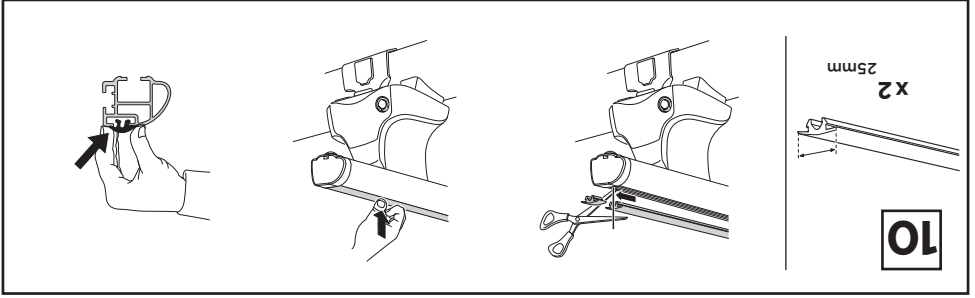

- UK Заміняць наперад
- BG Замени напредованно
- CS Pokrýtá bagazníka dokrécací
- FR Serrer alternativement chaque côté
- NL Afwisselend aan de linker- en de rechterkant aandraaien
- IT Alternare il serraggio delle viti
- ES Apertare alternativamente
- PT Aperte alternadamente
- SV Dra åt växelvis
- DK Spænd skiftevis
- NO Trekk til vekselvis
- FI Kiertä vuorotellen
- ET Pinguldage vaheldumisi
- LV Pieveicēt pamīšus
- LT Užsukinkitė pakaitomis
- PL Srdub dokrécací naprzemiennie
- RU Замениайте попеременно
- TH ផ្លាស់ប្តូរមុខ
- KO 좌우로 교체
- JA 左右交互に締めつける
- ZH 交替拧紧
- HE פרוט גרם
- AR ٲرفٲر ٲرٲر
- TR Dönüştürmü skirin
- EL Δφλυγείτε εναλλάξ
- HU Egyarástól függetlenül szorítandó
- RO Strângereți alternativ
- HR/BIH Naizmjenično zategnite
- SL Privijajte izmenično
- SK Dotáňujte štrédavo
- Privijajte izmenično
- TR Dönüştürmü skirin

- EN Tighten alternately
- DE Die Schrauben abwechselnd anziehen
- FR Serrer alternativement chaque côté
- NL Afwisselend aan de linker- en de rechterkant aandraaien
- IT Alternare il serraggio delle viti
- ES Apertare alternativamente
- PT Aperte alternadamente
- SV Dra åt växelvis
- DK Spænd skiftevis
- NO Trekk til vekselvis
- FI Kiertä vuorotellen
- ET Pinguldage vaheldumisi
- LV Pieveicēt pamīšus
- LT Užsukinkitė pakaitomis
- PL Srdub dokrécací naprzemiennie
- RU Замениайте попеременно

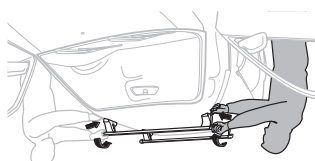

9

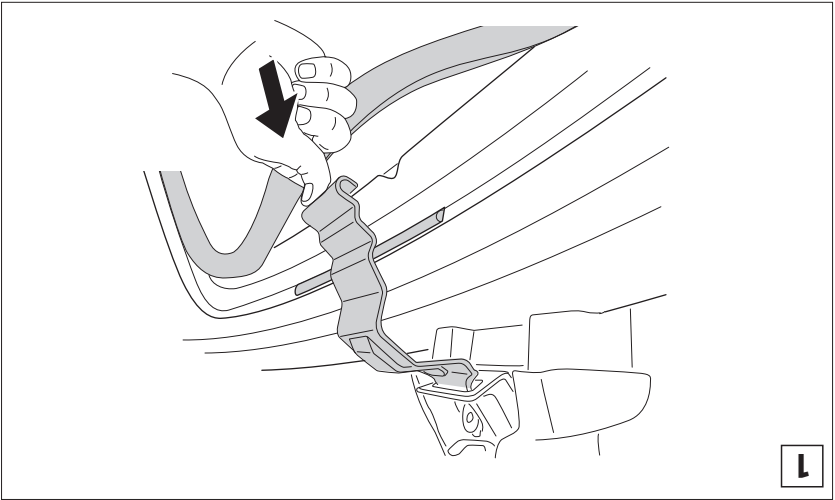
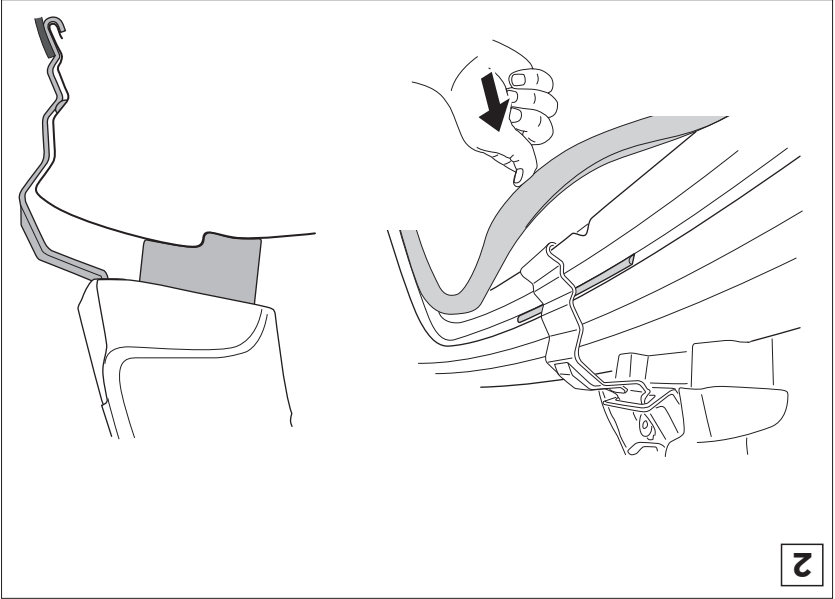

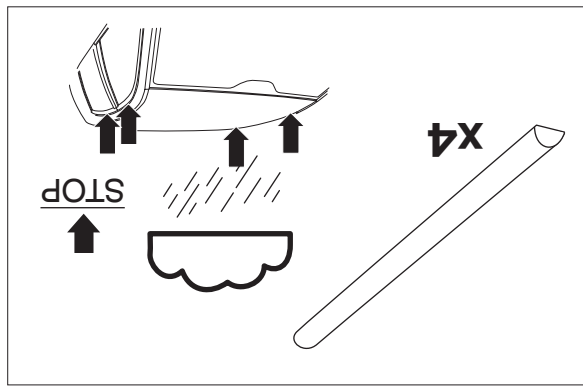
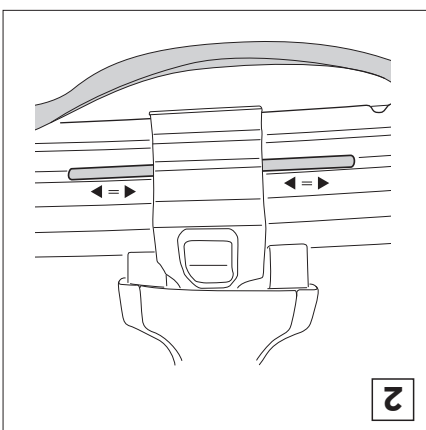
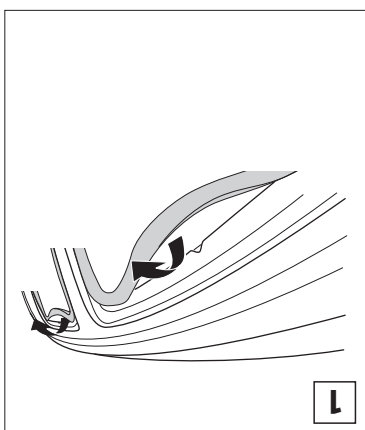
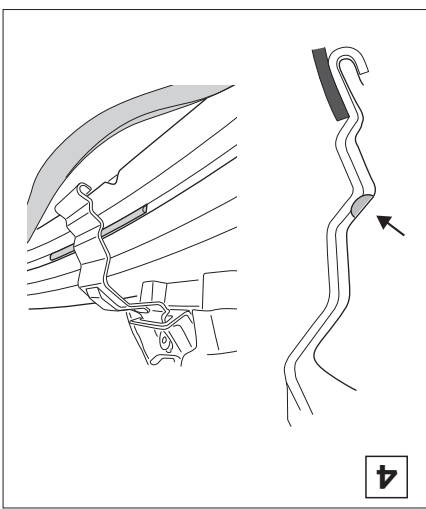
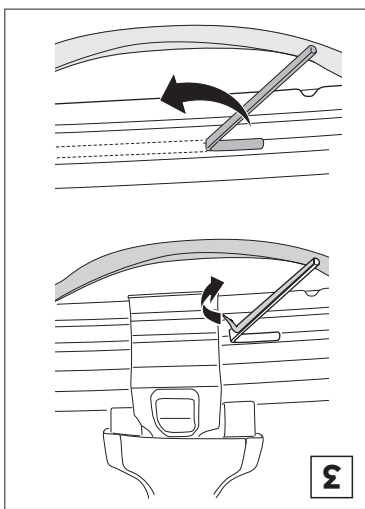

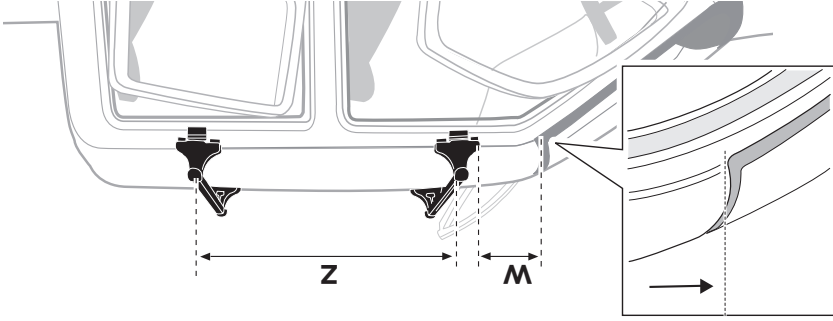

	X mm	Y mm	X inch	Y inch
CHEVROLET Colorado, 4-dr Crew Cab, 15-	250 mm	700 mm	9 7/8"	27 1/2"
CHEVROLET S10, 4-dr Double Cab, 12-	250 mm	700 mm	9 7/8"	27 1/2"
GMC Canyon, 4-dr Crew Cab, 15-	250 mm	700 mm	9 7/8"	27 1/2"
HOLDEN Colorado, 4-dr Double Cab, 12-	250 mm	700 mm	9 7/8"	27 1/2"
ISUZU D-Max, 4-dr Crew Cab, 12-	250 mm	700 mm	9 7/8"	27 1/2"

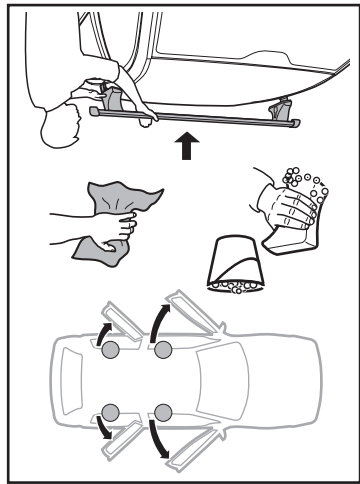
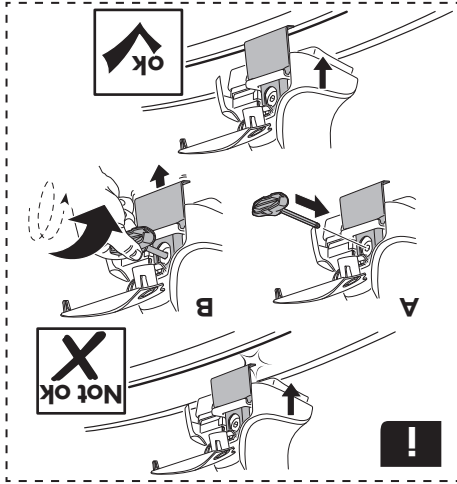

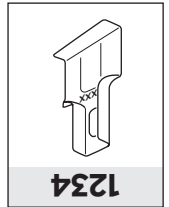
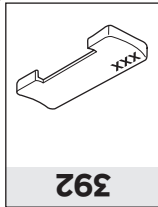
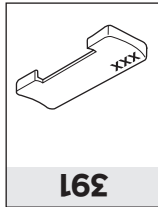
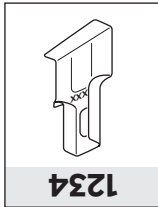
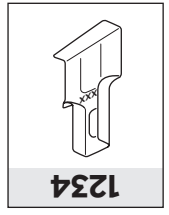
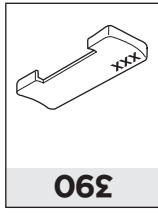
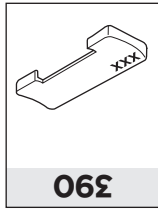
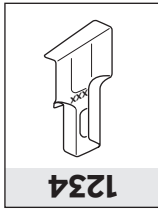
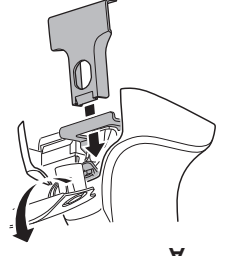
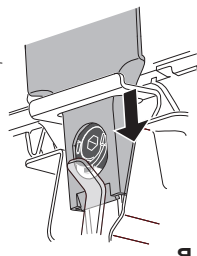
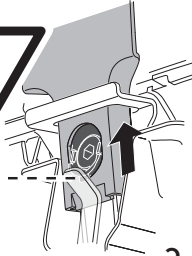
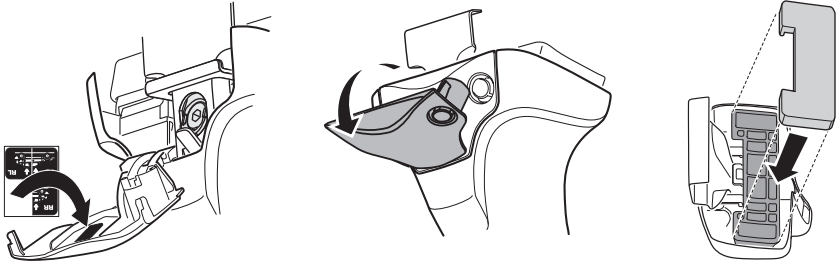

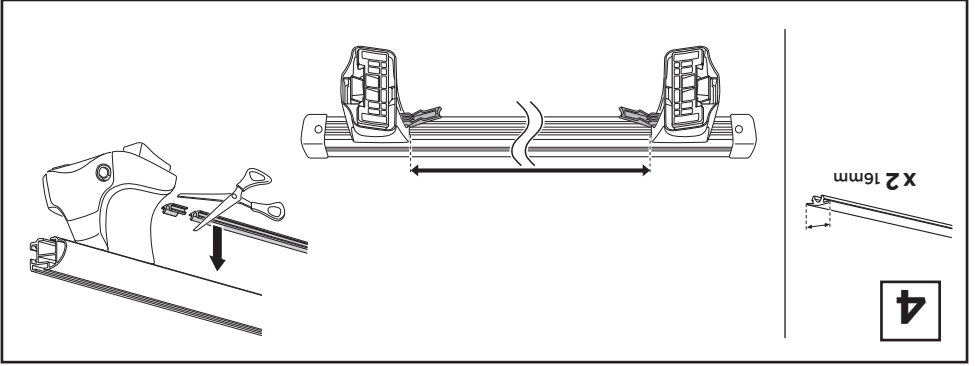

- CHEVROLET Colorado, 4-dr Crew Cab, 15-
- CHEVROLET S10, 4-dr Double Cab, 12-
- GMC Canyon, 4-dr Crew Cab, 15-
- HOLDEN Colorado, 4-dr Double Cab, 12-
- ISUZU D-Max, 4-dr Crew Cab, 12-



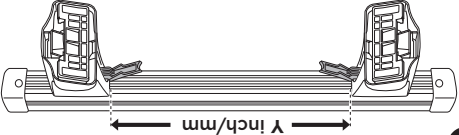

1006	35,5	ISUZU D-Max, 4-dr Crew Cab, 12-
1006	35,5	HOLDEN Colorado, 4-dr Double Cab, 12-
1006	35,5	GMC Canyon, 4-dr Crew Cab, 15-
1006	35,5	CHEVROLET S10, 4-dr Double Cab, 12-
1006	35,5	CHEVROLET Colorado, 4-dr Crew Cab, 15-

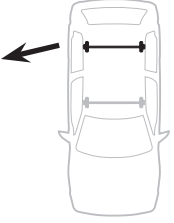
Y inch Y mm



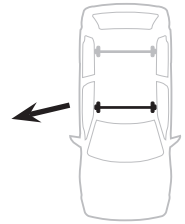
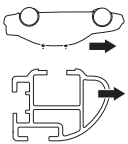

1031	38	ISUZU D-Max, 4-dr Crew Cab, 12-
1031	38	HOLDEN Colorado, 4-dr Double Cab, 12-
1031	38	GMC Canyon, 4-dr Crew Cab, 15-
1031	38	CHEVROLET S10, 4-dr Double Cab, 12-
1031	38	CHEVROLET Colorado, 4-dr Crew Cab, 15-

X inch X mm

3

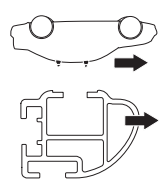
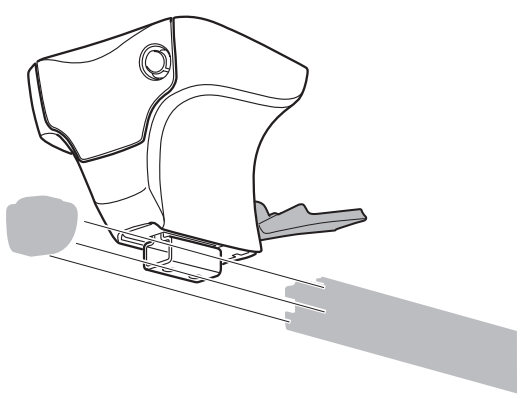
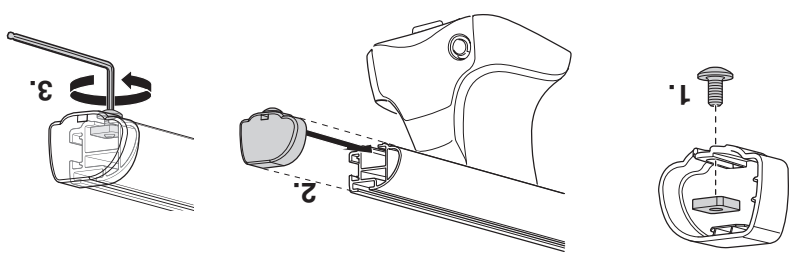

2

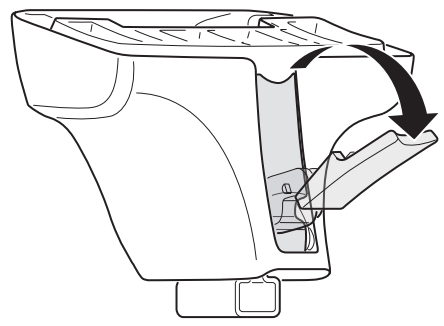

1

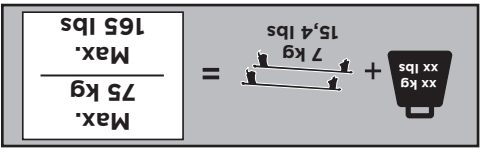
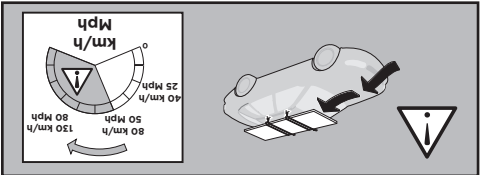
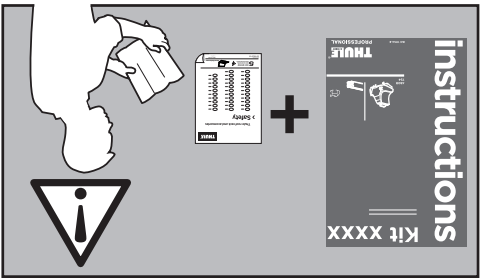
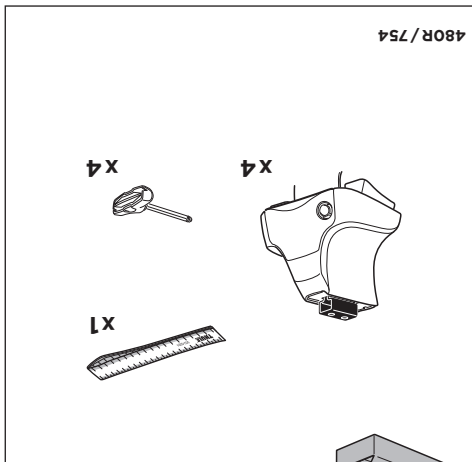
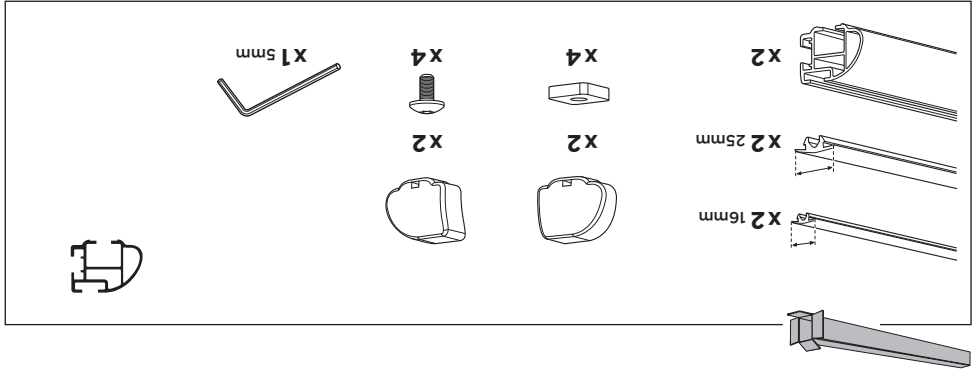
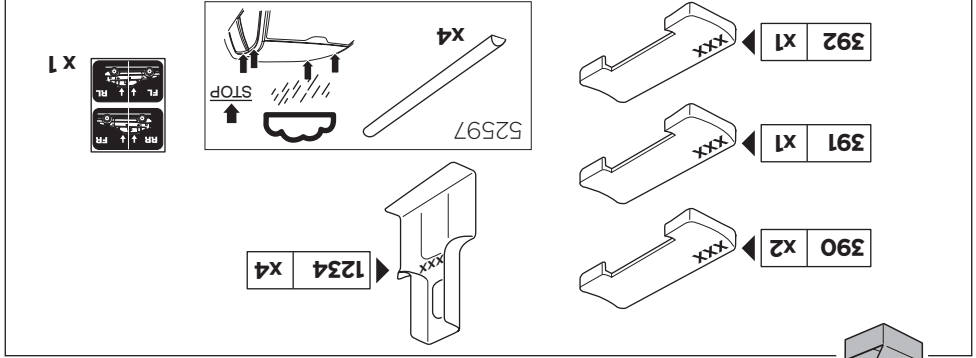

instructions

Kit 1783

- CHEVROLET Colorado, 4-dr Crew Cab, 15-
- CHEVROLET S10, 4-dr Double Cab, 12-
- GMC Canyon, 4-dr Crew Cab, 15-
- HOLDEN Colorado, 4-dr Double Cab, 12-
- ISUZU D-Max, 4-dr Crew Cab, 12-

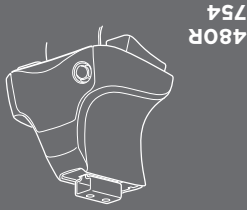
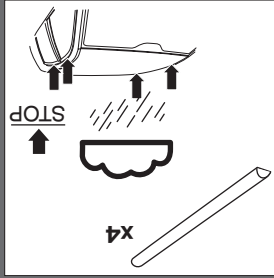

480R
754

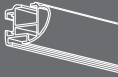

PROFESSIONAL

ISO 11154-E

THULE
SWEDEN