

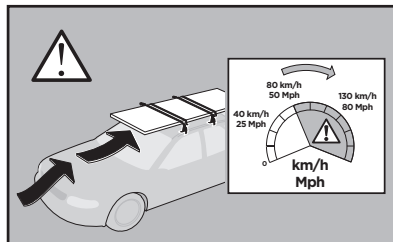

Thule Rapid System Kit 1745

> Instructions

CHEVROLET Silverado, 4-dr Crew Cab, 14-
CHEVROLET Silverado, 4-dr Double Cab, 14-
GMC Sierra, 4-dr Crew Cab, 14-
GMC Sierra, 4-dr Double Cab, 14-

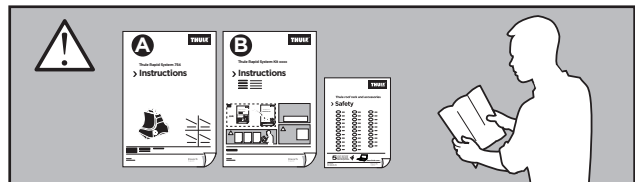
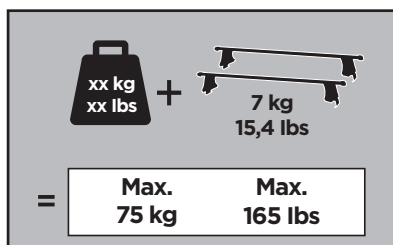
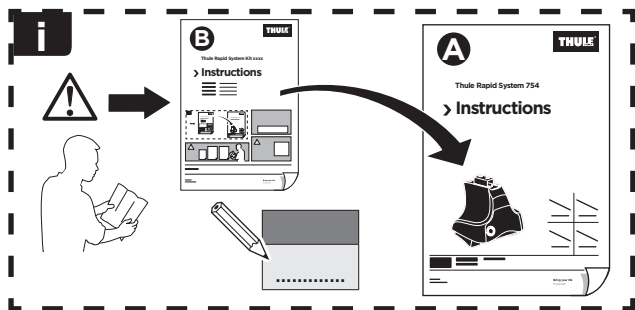

ISO 11154-E

141745
C.20150410
519-1745-01

Bring your life
thule.com

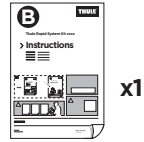
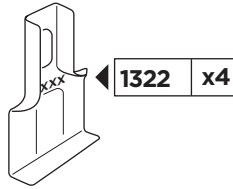
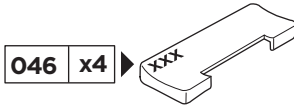
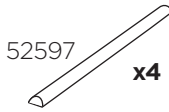

1

	X (scale)	X (mm)	X (inch)
CHEVROLET Silverado , 4-dr Crew Cab, 14-	55,5	1206	47 1/2
CHEVROLET Silverado , 4-dr Double Cab, 14-	55,5	1206	47 1/2
GMC Sierra , 4-dr Crew Cab, 14-	55,5	1206	47 1/2
GMC Sierra , 4-dr Double Cab, 14-	55,5	1206	47 1/2

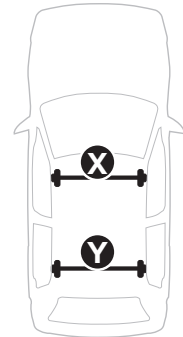
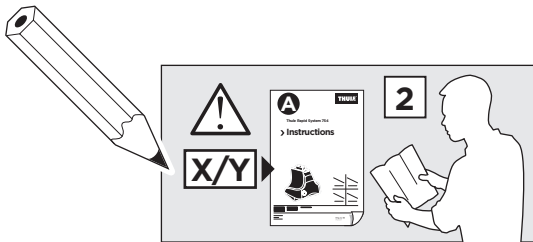

	Y (scale)	Y (mm)	Y (inch)
CHEVROLET Silverado , 4-dr Crew Cab, 14-	55	1201	47 1/4
CHEVROLET Silverado , 4-dr Double Cab, 14-	55	1201	47 1/4
GMC Sierra , 4-dr Crew Cab, 14-	55	1201	47 1/4
GMC Sierra , 4-dr Double Cab, 14-	55	1201	47 1/4

2

CHEVROLET Silverado, 4-dr Crew Cab, 14-

CHEVROLET Silverado, 4-dr Double Cab, 14-

GMC Sierra, 4-dr Crew Cab, 14-

GMC Sierra, 4-dr Double Cab, 14-

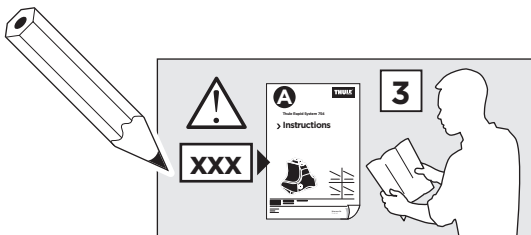
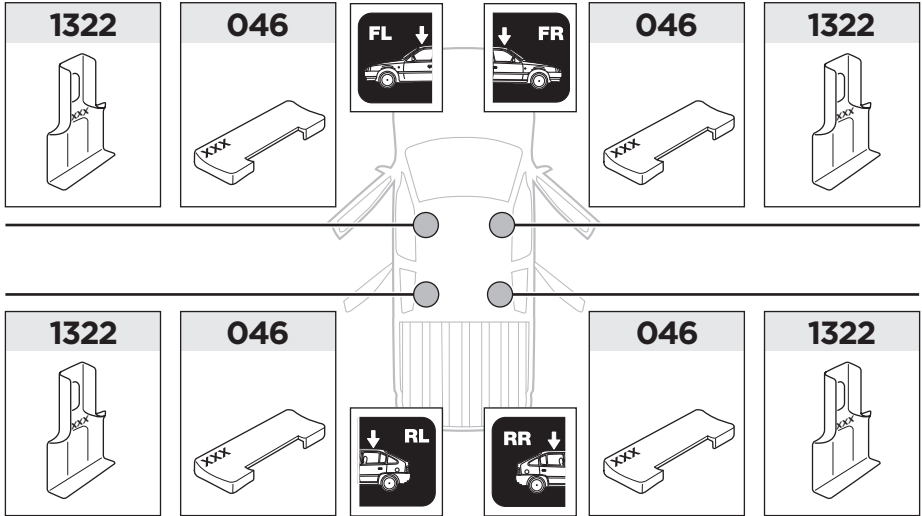

3



	W (mm)	Z (mm)	W (inch)	Z (inch)
CHEVROLET Silverado, 4-dr Crew Cab, 14-	295	700	11 5/8	27 1/2
CHEVROLET Silverado, 4-dr Double Cab, 14-	295	700	11 5/8	27 1/2
GMC Sierra, 4-dr Crew Cab, 14-	295	700	11 5/8	27 1/2
GMC Sierra, 4-dr Double Cab, 14-	295	700	11 5/8	27 1/2

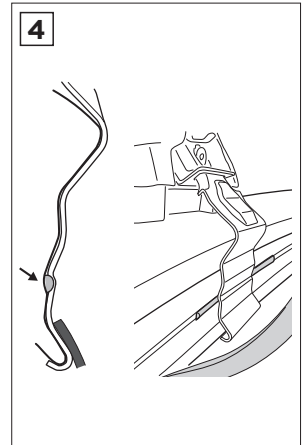
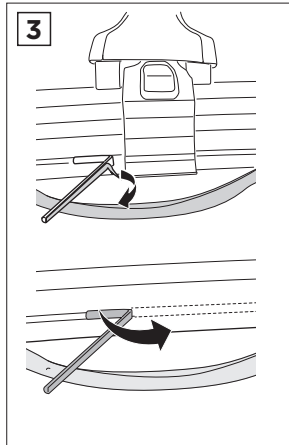
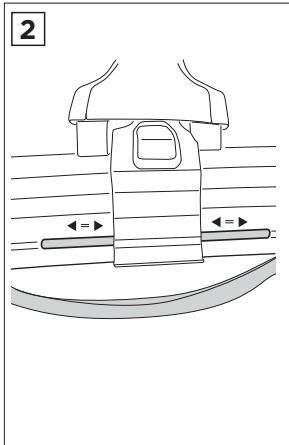
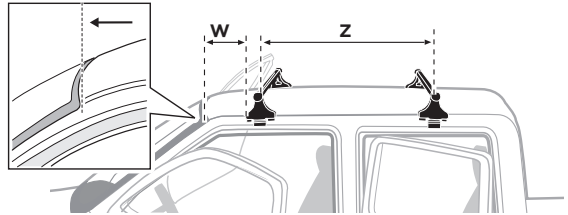
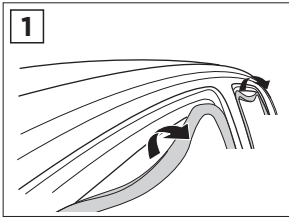

4

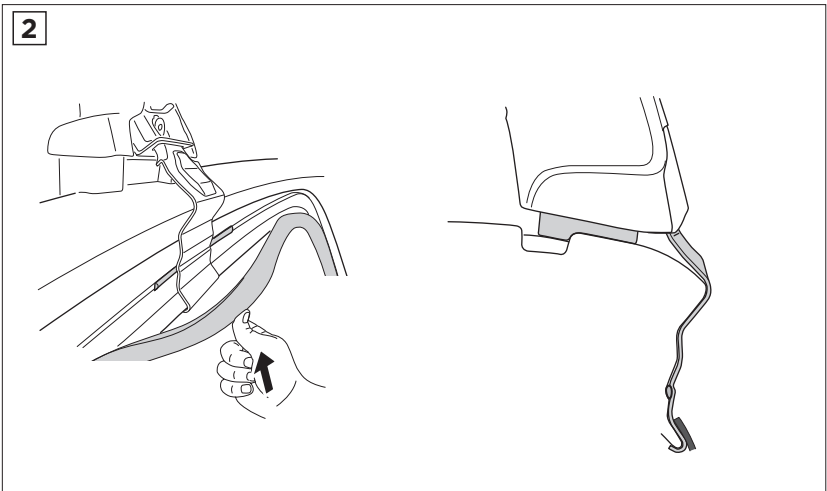
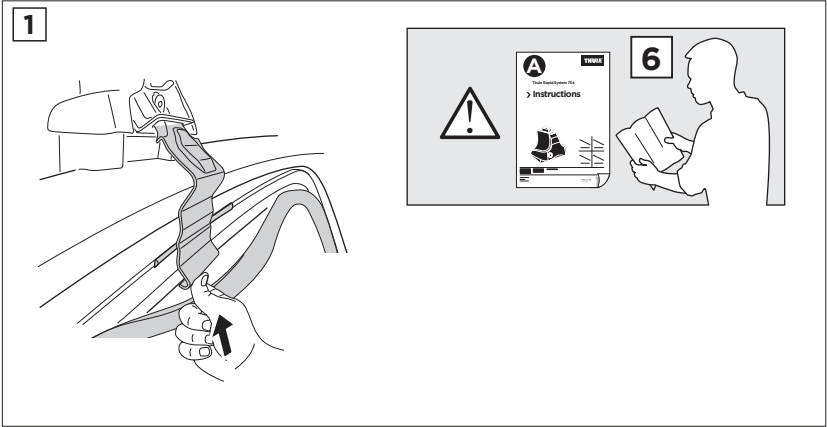

Thule Sweden AB, Box 69, 330 33 Hillerstorp, SWEDEN
Thule Inc., 42 Silvermine Road, Seymour, Connecticut 06483, USA

info@thule.com
Phone: 800-238-2388

 www.thule.com

» PART OF THULE GROUP

© Thule Group 2015. All rights reserved.

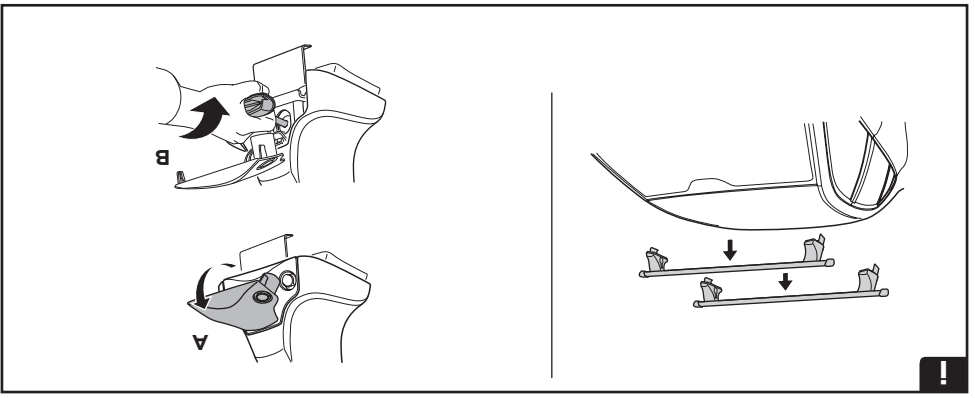
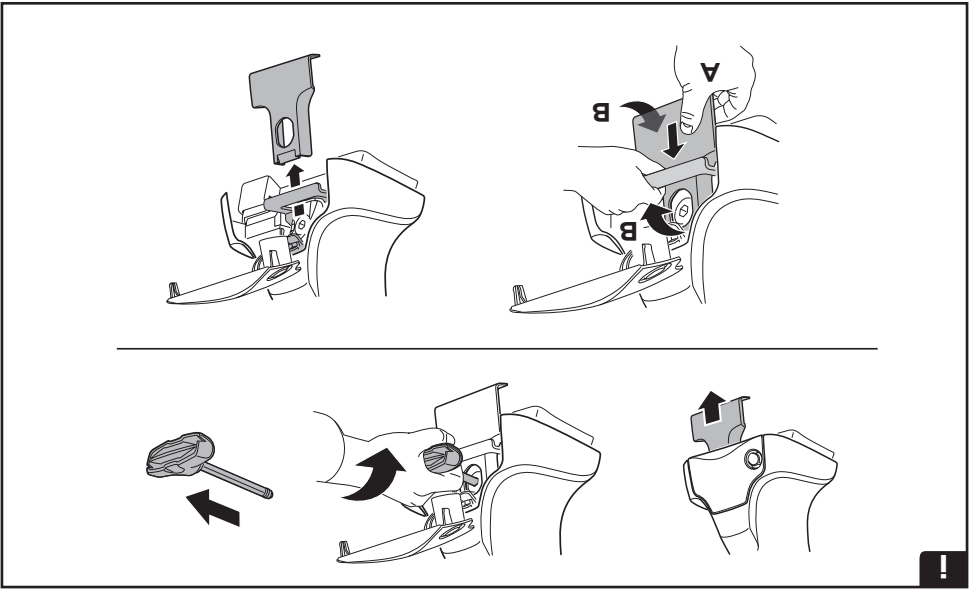

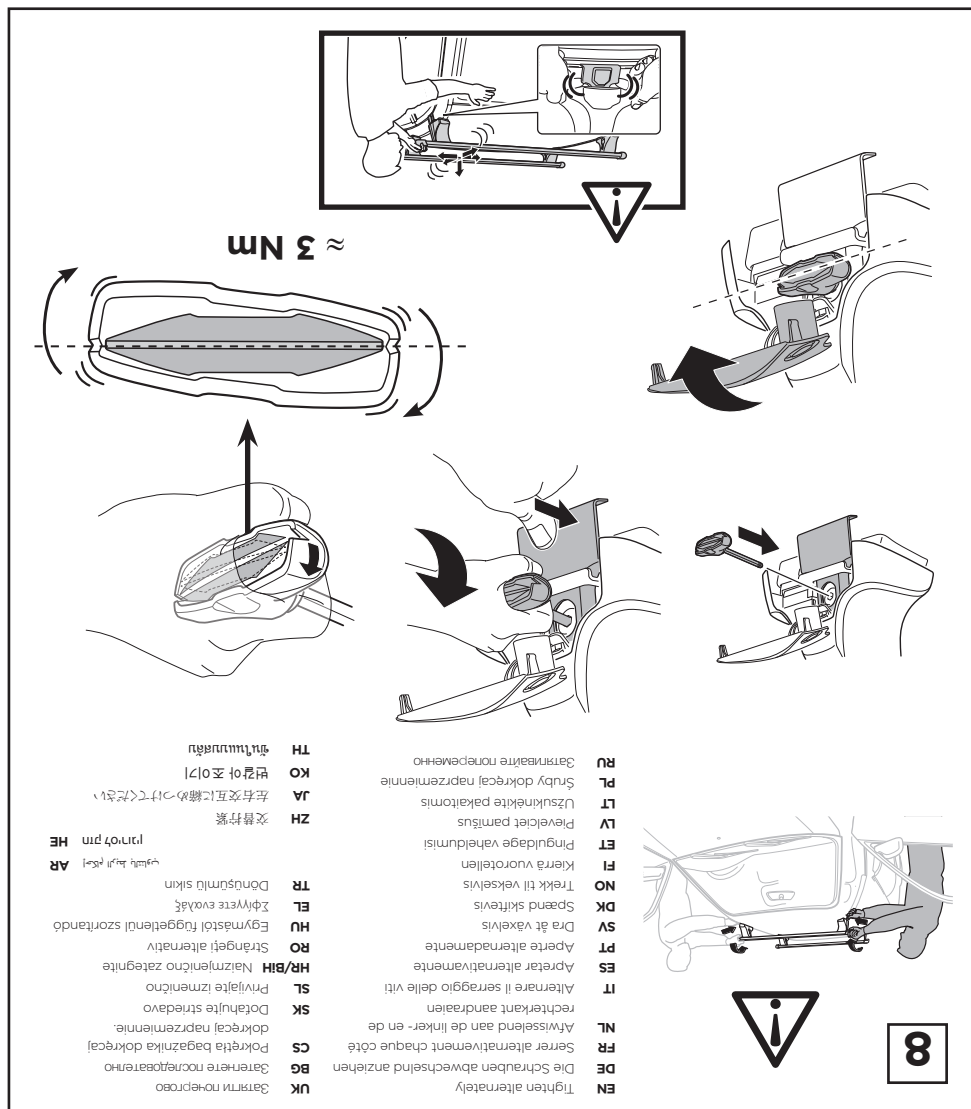
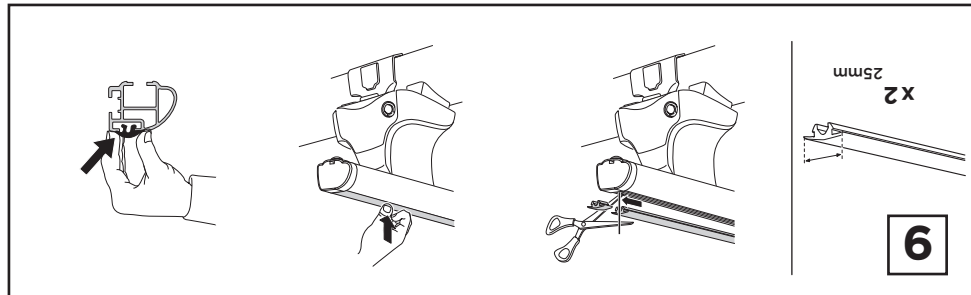

- UK Заміняти попарно
- BG Замени попарно
- FR Serrer alternativement chaque côté
- NL Afwisselend aan de linker- en de rechterkant aandraaien
- IT Alternare il serraggio delle viti
- ES Aprete alternativamente
- PT Aperte alternadamente
- SV Dra åt växelvis
- DK Spænd skiftevis
- NO Trekk til vekselvis
- FI Kierä vuorotellen
- ET Pinguldage vaheldumisi!
- LV Pievieciēt pamīšus
- LT Užsukinkite pakaitomis
- PL Srdub dokrecal naprzemiennie
- RU Завинчивайте попережно
- TH วนไขนั้มนั้
- KO ㅊㄱㄴ ㅊㄱㄴ
- JA 左右交互に締めつける
- ZH 交替拧紧
- HE փոխփոխ փոխփոխ
- AR ڤڤوڤ ڤڤوڤ
- TR Dönüşümü sikin
- EL ԷփփյէԷ Էփփյէ
- HU Egyarástól függetlenül szorítandó
- RO Strângeti alternativ
- HR/BIH Naizmjenično zategnite
- SL Privijajte izmenično
- SK Dotáňujete štriedavo
- SK Privijajte izmenično
- CS Pokręta bagaznıka dokřecaj
- BG Ȥamenite napřezmıenno
- SK Dotáňujete štriedavo
- HR/BIH Naizmjenično zategnite
- RO Strângeti alternativ
- HU Egyarástól függetlenül szorítandó
- EL ԷփփյէԷ Էփփյէ
- TR Dönüşümü sikin
- AR ڤڤوڤ ڤڤوڤ
- HE փոխփոխ փոխփոխ
- ZH 交替拧紧
- JA 左右交互に締めつける
- KO ㅊㄱㄴ ㅊㄱㄴ
- TH วนไขนั้มนั้

≈ 3 Nm

8

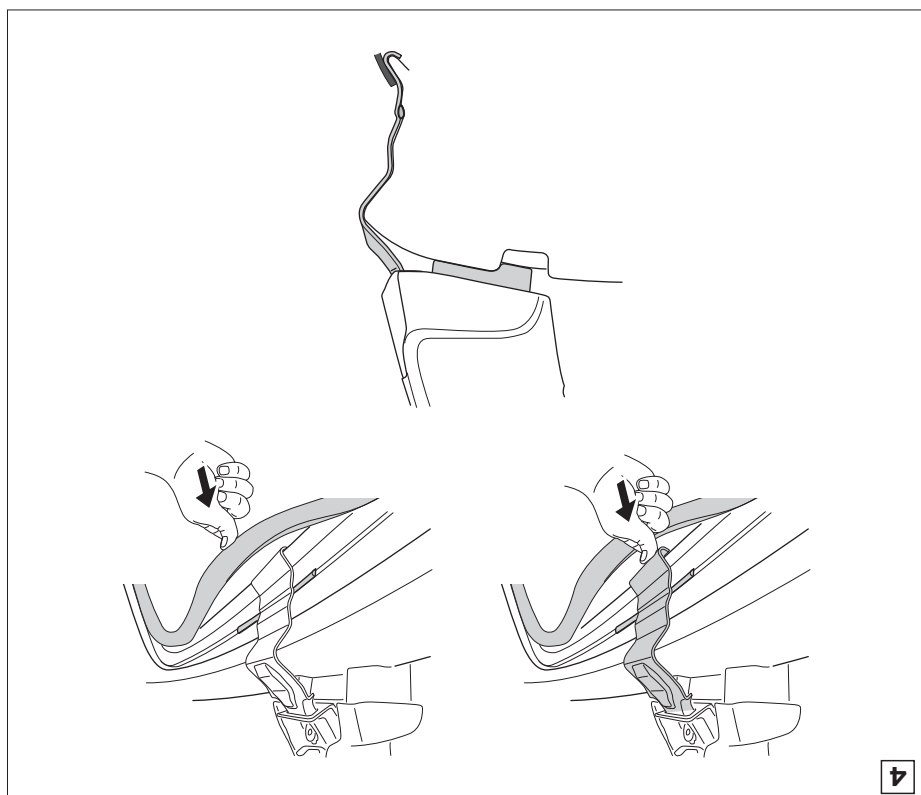

4

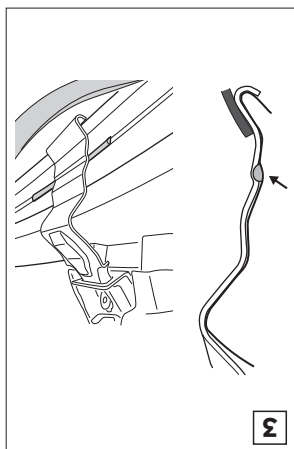

3

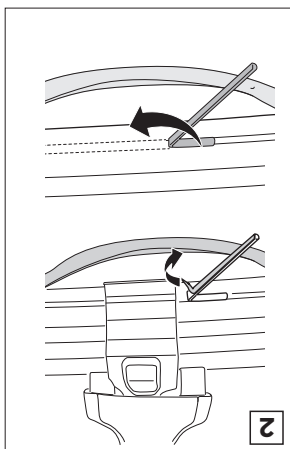

2

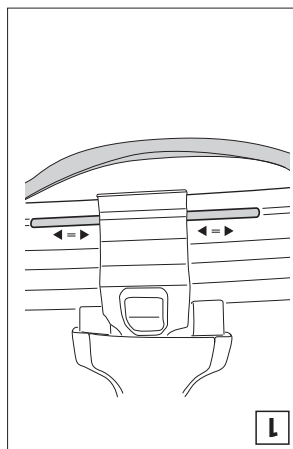

1

7

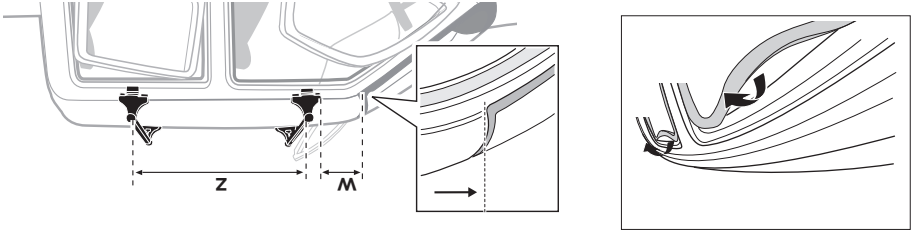

	X mm	Y mm	X inch	Y inch
CHEVROLET Silverado, 4-dr Crew Cab, 14-	295	700	11 5/8	27 1/2
CHEVROLET Silverado, 4-dr Double Cab, 14-	295	700	11 5/8	27 1/2
GMC Sierra, 4-dr Crew Cab, 14-	295	700	11 5/8	27 1/2
GMC Sierra, 4-dr Double Cab, 14-	295	700	11 5/8	27 1/2

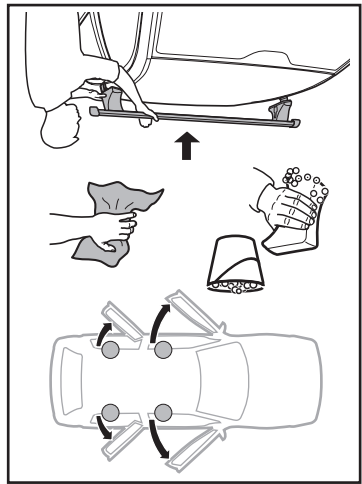
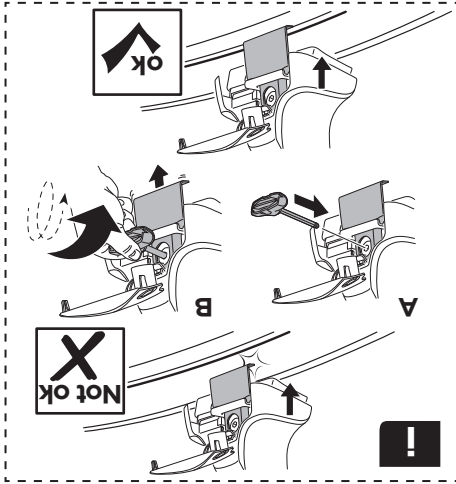

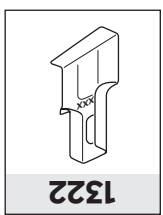
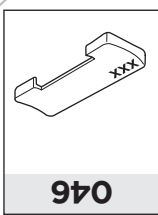
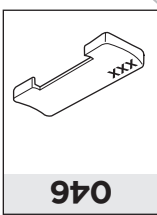
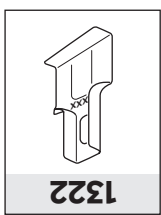
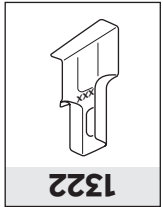
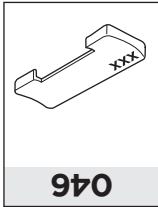
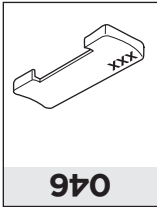
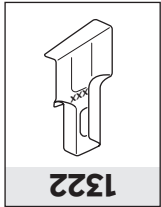
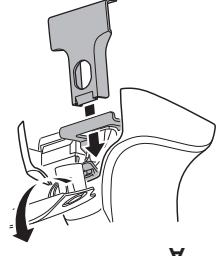
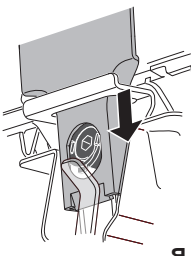
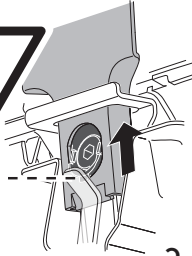
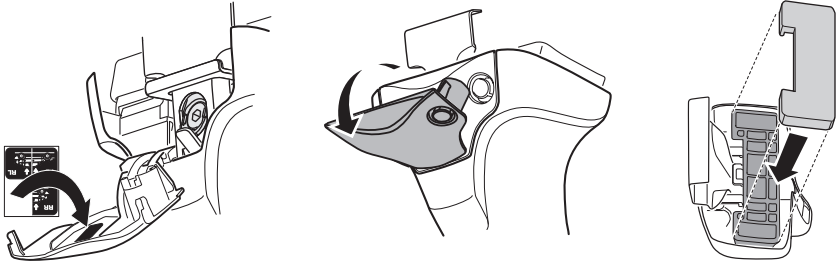

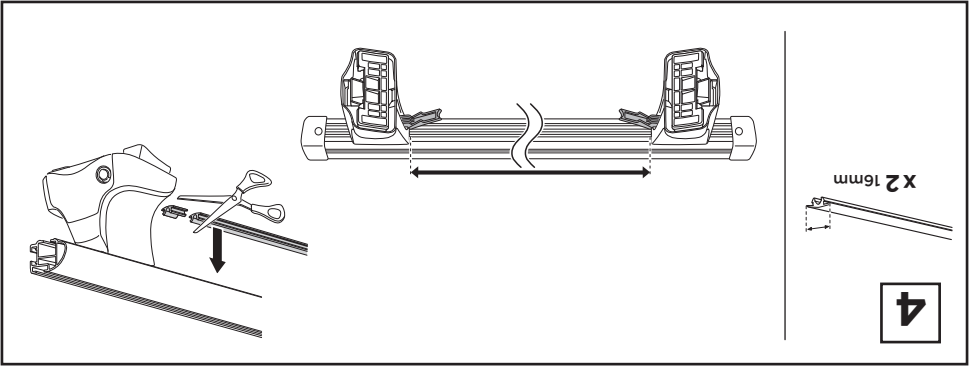

- CHEVROLET Silverado, 4-dr Crew Cab, 14-**
- CHEVROLET Silverado, 4-dr Double Cab, 14-**
- GMC Sierra, 4-dr Crew Cab, 14-**
- GMC Sierra, 4-dr Double Cab, 14-**



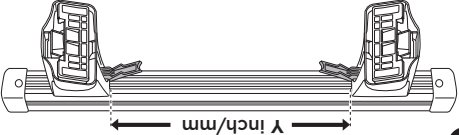

1201	47 1/4	GMC Sierra, 4-dr Double Cab, 14-
1201	47 1/4	GMC Sierra, 4-dr Crew Cab, 14-
1201	47 1/4	CHEVROLET Silverado, 4-dr Double Cab, 14-
1201	47 1/4	CHEVROLET Silverado, 4-dr Crew Cab, 14-

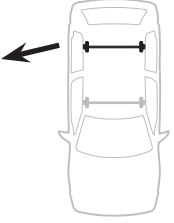
Y inch Y mm



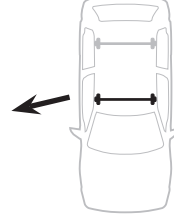
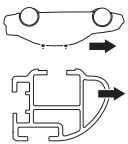

1206	47 1/2	GMC Sierra, 4-dr Double Cab, 14-
1206	47 1/2	GMC Sierra, 4-dr Crew Cab, 14-
1206	47 1/2	CHEVROLET Silverado, 4-dr Double Cab, 14-
1206	47 1/2	CHEVROLET Silverado, 4-dr Crew Cab, 14-

X inch X mm

3

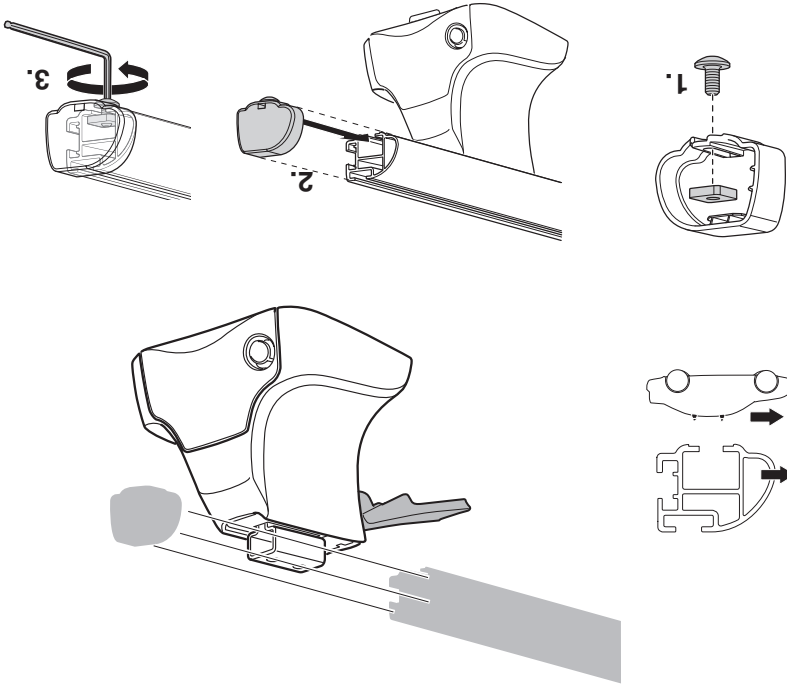

2

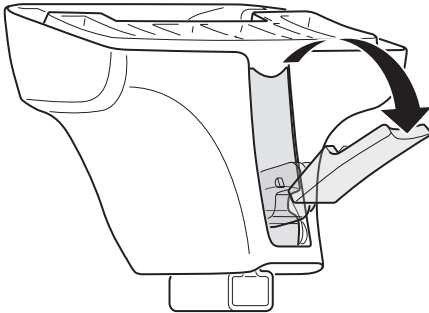

1

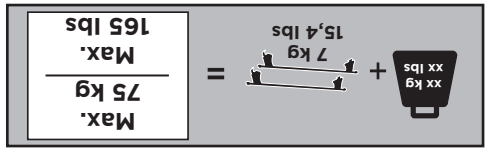
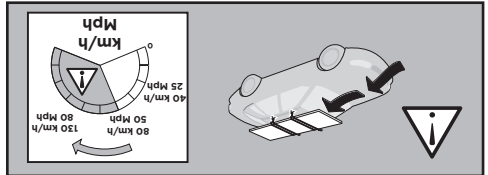
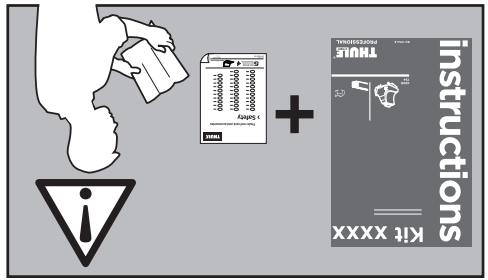
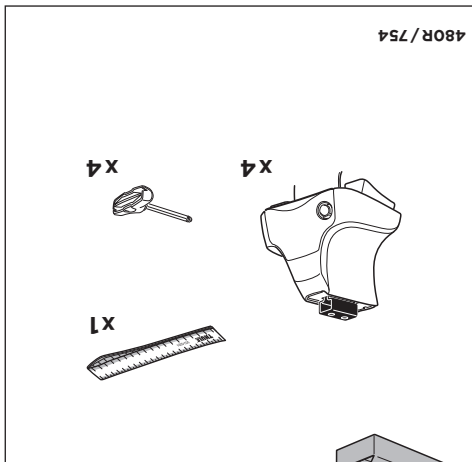
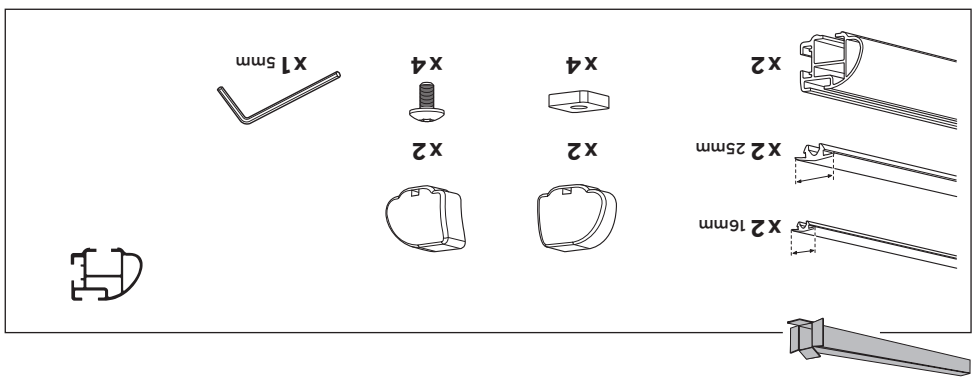
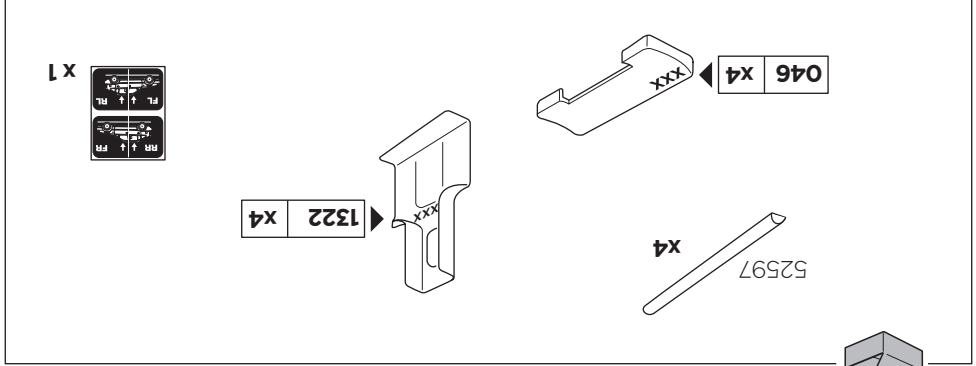

instructions

Kit 1745

CHEVROLET Silverado, 4-dr Crew Cab, 14-
CHEVROLET Silverado, 4-dr Double Cab, 14-
GMC Sierra, 4-dr Crew Cab, 14-
GMC Sierra, 4-dr Double Cab, 14-

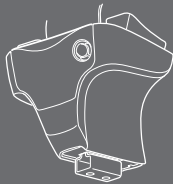

480R
754



ISO 11154-E

PROFESSIONAL

THULE
SWEDEN