

Kit 1469

HYUNDAI H-1, 5-dr Van, 08-*

HYUNDAI iLoad, 5-dr Van, 08-**

HYUNDAI iMax, 5-dr Bus, 08-**

HYUNDAI Starex, 5-dr Van, 08-*

* with dual sliding doors

** with dual sliding doors (Asia)

480R
754

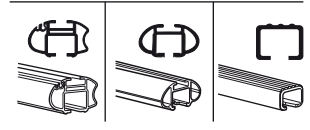
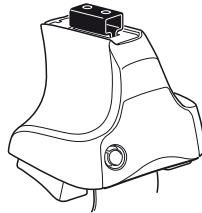

480

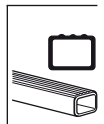
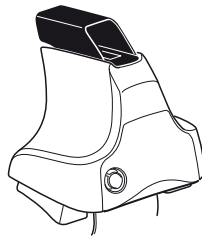

750

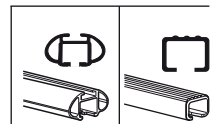
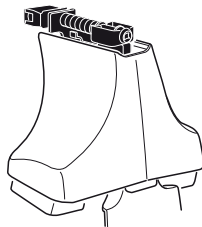

Kit



3

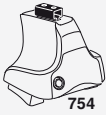

754

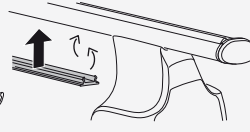
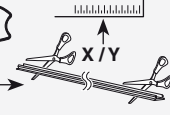

750

1

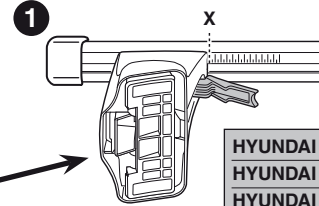

2

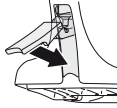

| | X |
|-------------------------------|------|
| HYUNDAI H-1, 5-dr Van, 08- | 59,5 |
| HYUNDAI iLoad, 5-dr Van, 08- | 59,5 |
| HYUNDAI iMax, 5-dr Bus, 08- | 59,5 |
| HYUNDAI Starex, 5-dr Van, 08- | 59,5 |

1

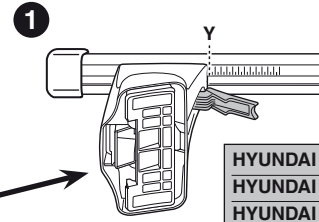

2



| | Y |
|-------------------------------|------|
| HYUNDAI H-1, 5-dr Van, 08- | 55,5 |
| HYUNDAI iLoad, 5-dr Van, 08- | 55,5 |
| HYUNDAI iMax, 5-dr Bus, 08- | 55,5 |
| HYUNDAI Starex, 5-dr Van, 08- | 55,5 |



480R



480

1

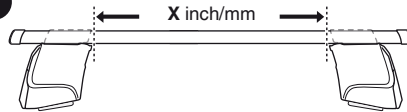

2

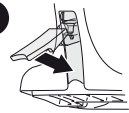

| | X inch | X mm |
|-------------------------------|--------|---------|
| HYUNDAI H-1, 5-dr Van, 08- | 49" | 1246 mm |
| HYUNDAI iLoad, 5-dr Van, 08- | 49" | 1246 mm |
| HYUNDAI iMax, 5-dr Bus, 08- | 49" | 1246 mm |
| HYUNDAI Starex, 5-dr Van, 08- | 49" | 1246 mm |

1

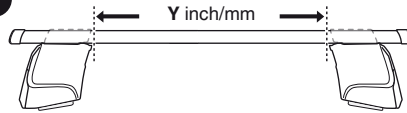

2

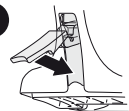

| | Y inch | Y mm |
|-------------------------------|---------|---------|
| HYUNDAI H-1, 5-dr Van, 08- | 47 1/2" | 1206 mm |
| HYUNDAI iLoad, 5-dr Van, 08- | 47 1/2" | 1206 mm |
| HYUNDAI iMax, 5-dr Bus, 08- | 47 1/2" | 1206 mm |
| HYUNDAI Starex, 5-dr Van, 08- | 47 1/2" | 1206 mm |

4

HYUNDAI H-1, 5-dr Van, 08-
 HYUNDAI iLoad, 5-dr Van, 08-
 HYUNDAI iMax, 5-dr Bus, 08-
 HYUNDAI Starex, 5-dr Van, 08-

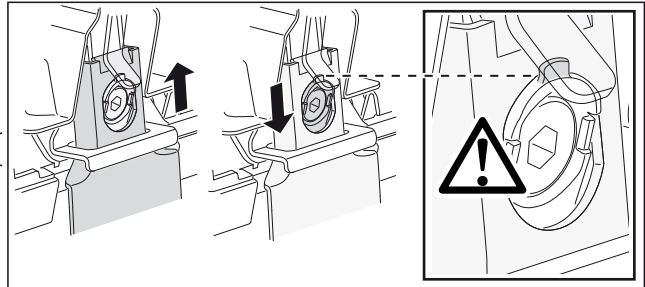
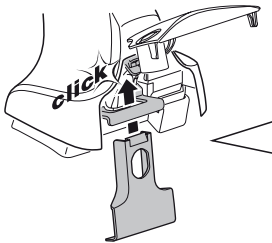
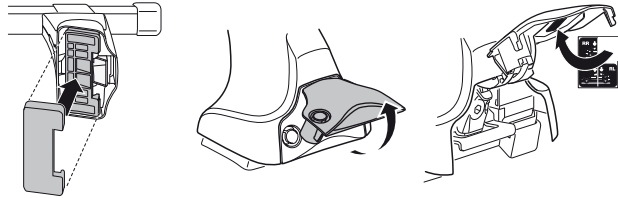
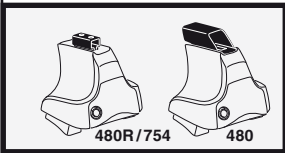
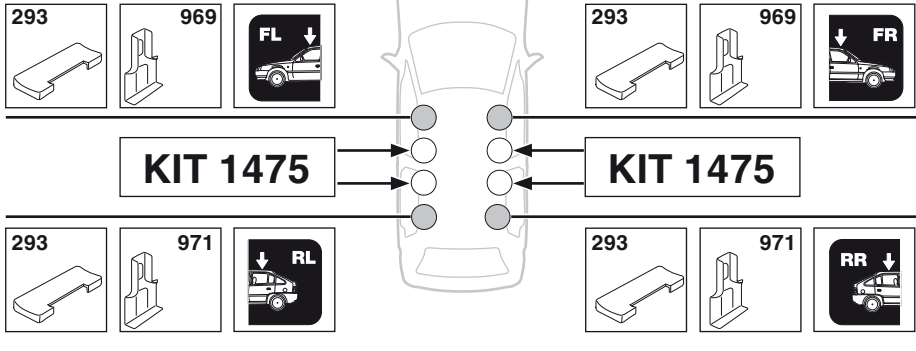

5

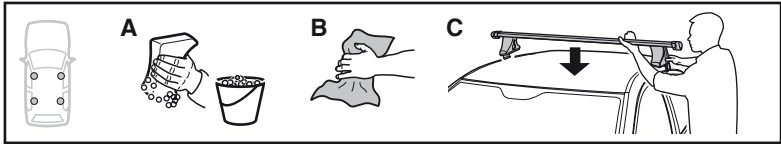

| | X mm | Y mm | X inch | Y inch |
|-------------------------------|--------|---------|--------|--------|
| HYUNDAI H-1, 5-dr Van, 08- | 380 mm | 1930 mm | 15" | 76" |
| HYUNDAI iLoad, 5-dr Van, 08- | 380 mm | 1930 mm | 15" | 76" |
| HYUNDAI iMax, 5-dr Bus, 08- | 380 mm | 1930 mm | 15" | 76" |
| HYUNDAI Starex, 5-dr Van, 08- | 380 mm | 1930 mm | 15" | 76" |

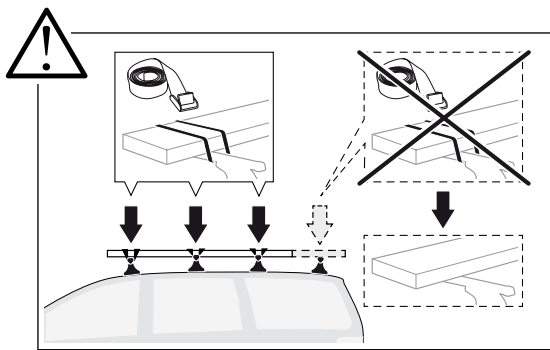
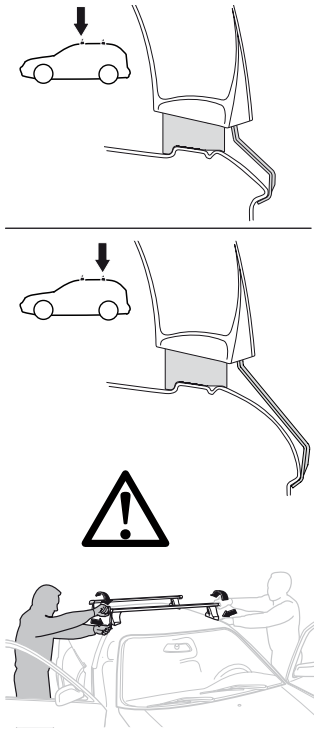
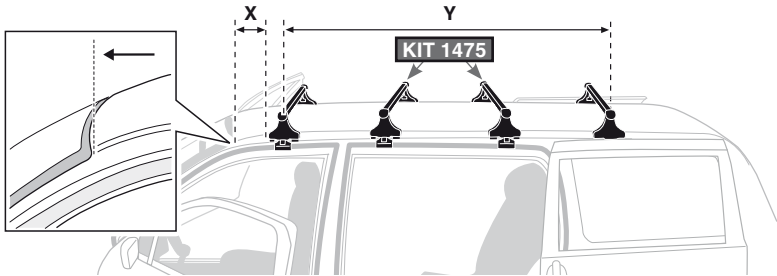

- | | | | |
|--------------|---|------------|---|
| GB/US | Tighten alternately | CZ | Pokręťla bagazníka dokręčaj dokręčaj naprzemiennie. |
| D | Die Schrauben abwechselnd anziehen | SK | Dotahujte striedavo |
| F | Serrer alternativement chaque côté | SLO | Privijajte izmenično. |
| NL | Afwisselend aan de linker- en de rechterkant aandraaien | HR | Naizmjenično zategnite |
| I | Alternare il serraggio delle viti | HU | Egy mástól függetlenül szorítandó |
| E | Apretar alternativamente | GR | Σφιγίγστε ενυλάξ |
| PT | Aperte alternadamente | TR | Dönüşümlü sıkın |
| S | Dra åt växelvis | 中文 | 交替拧紧 |
| FIN | Kierrä vuorotellen | 한국어 | 번갈아 가며 조이십시오. |
| EST | Pinguldage vaheldumisi | 日本語 | 交互に締め付けてください。 |
| LAT | Pievēlciēt pamišus | ไทย | ขันสลับสลับ |
| LIT | Užsukinėkite pakaitomis | | |
| PL | Śruby dokręcaj naprzemiennie | | |
| RU | Затягивайте попеременно | | |

6



480R/754



480

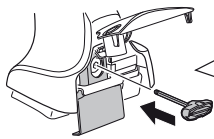

*
3 Nm



*

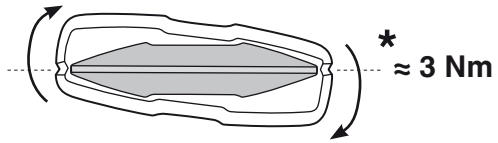

*
≈ 3 Nm

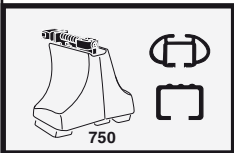
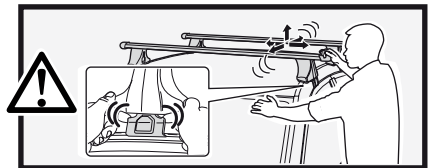

750

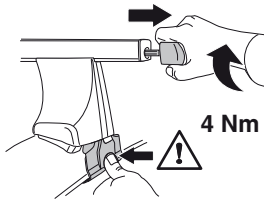

4 Nm

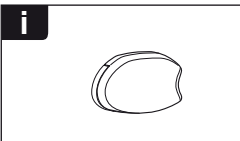
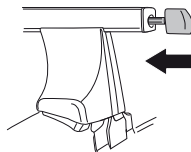

i

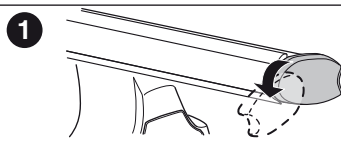

1

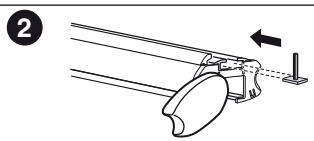

2

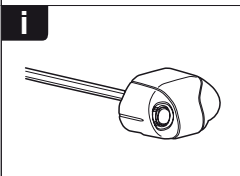

i

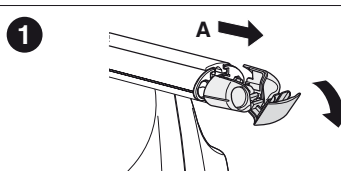

1

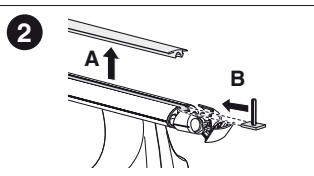

2

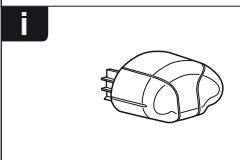

i

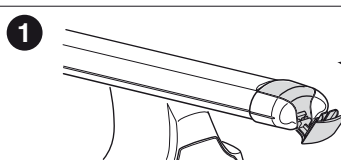

1

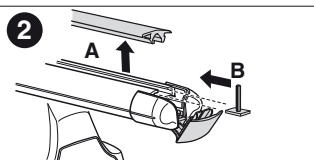

2



THULE
SWEDEN
**ONE
KEY
SYSTEM**



- 544 (x4)
- 596 (x6)
- 588 (x8)
- NA 510 (x10)
- EUR 452 (x12)
- ASIA





WW ▶ Thule Sweden AB, Box 69, 330 33 Hillerstorp, SWEDEN
NA ▶ Thule Inc., 42 Silvermine Road, Seymour, Connecticut 06483, USA

info@thule.com
customer.service@thule.com

www.thule.com

 www.thuleprofessional.com

 info@thule.com
customer.service@thule.com

 Thule Inc., 42 Silvermine Road, Seymour, Connecticut 06483, USA
 Thule Sweden AB, Box 69, 330 33 Hillerstorp, SWEDEN

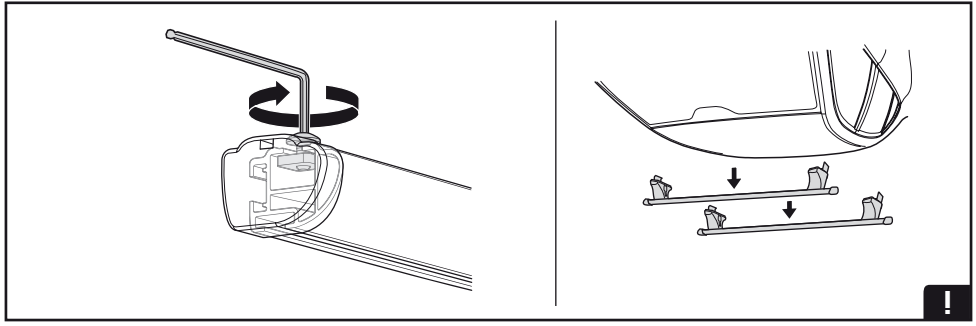
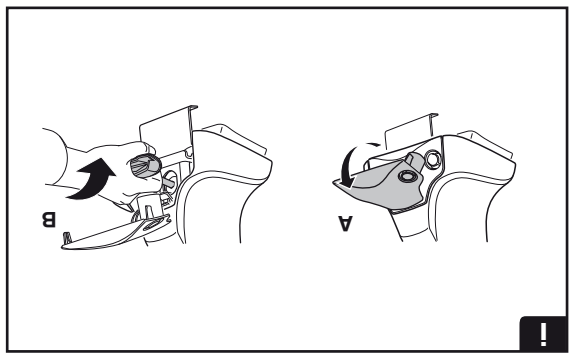
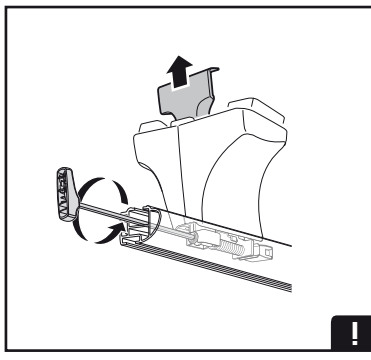
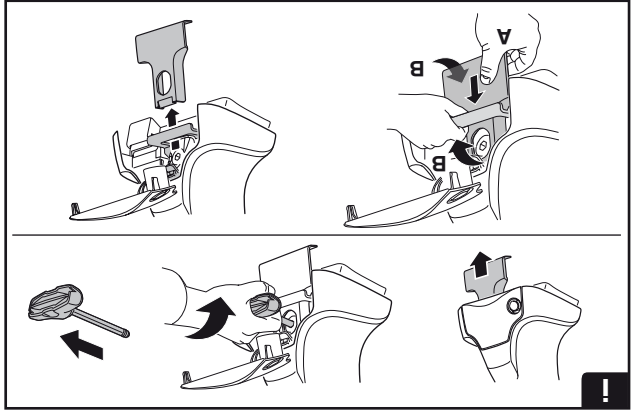
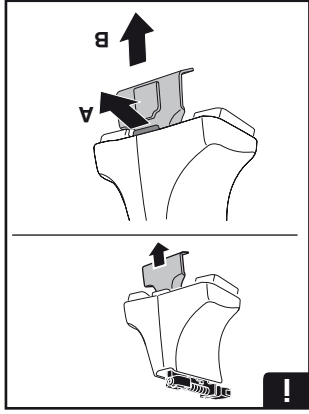

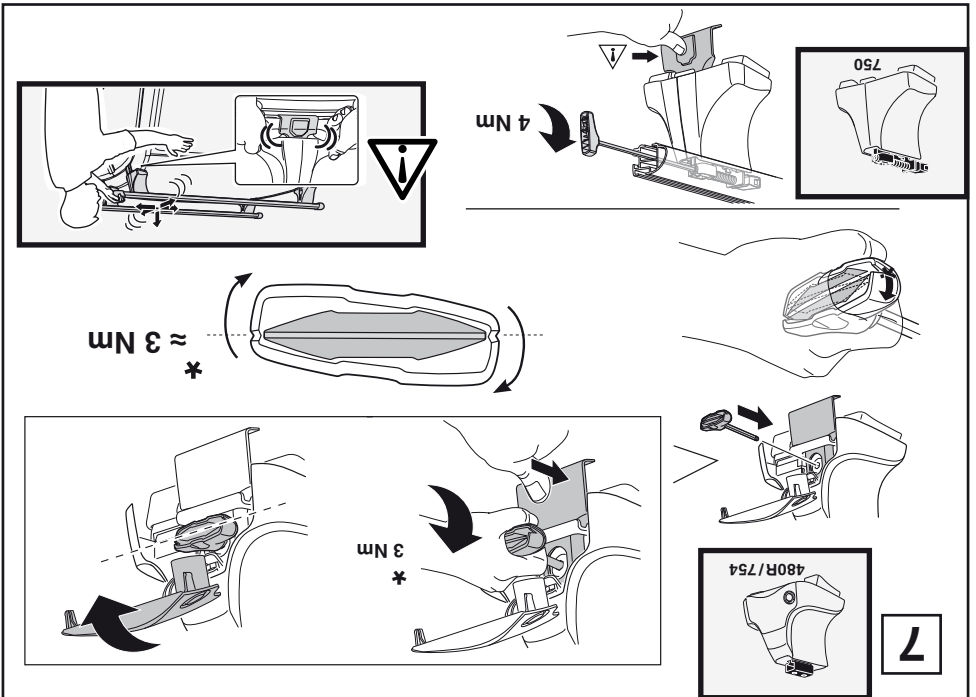
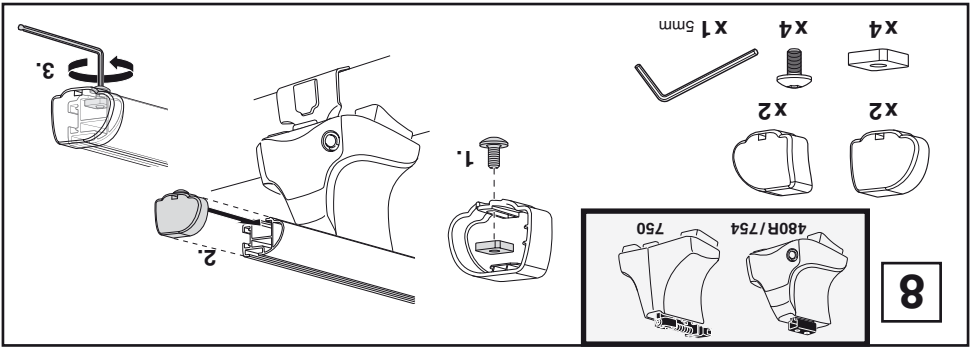
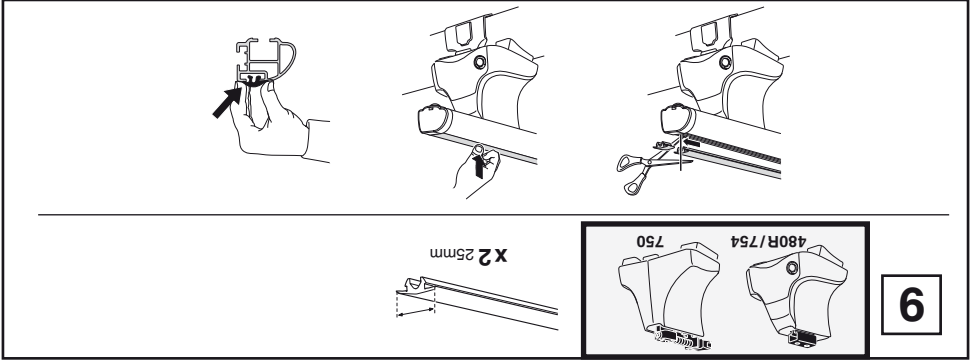

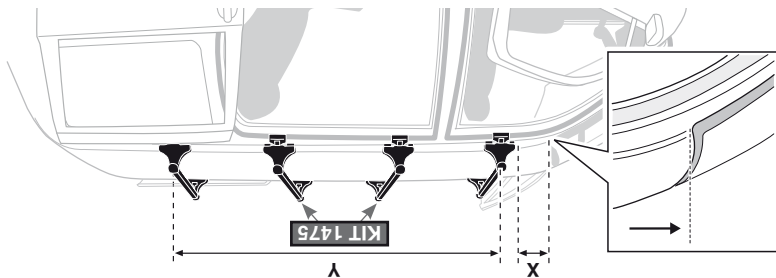
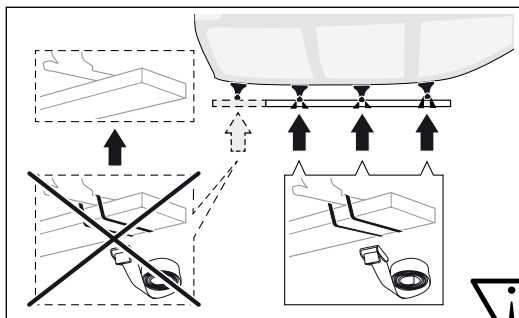
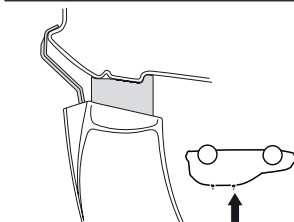
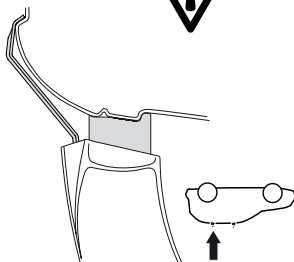
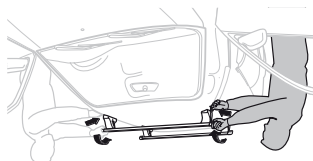

| | | | | | | | | |
|--|--|--|--|------------------------------|--------|---------|-----|-----|
| | | | | HUNDAI H-1, 5-dr Van, 08- | 380 mm | 1930 mm | 15" | 76" |
| | | | | HUNDAI Load, 5-dr Van, 08- | 380 mm | 1930 mm | 15" | 76" |
| | | | | HUNDAI Max, 5-dr Bus, 08- | 380 mm | 1930 mm | 15" | 76" |
| | | | | HUNDAI Starex, 5-dr Van, 08- | 380 mm | 1930 mm | 15" | 76" |

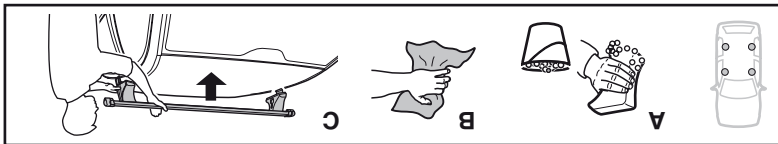

6

GB/US D Tighten alternately
F NL Serretter alternatief
I Serretter abwechselnd
RU S Sruby dokrecaj napremitelno
PL Usukniekcie pakalomis
LT Pielvelciot pamitus
LAT Pinguldage vaheldumisi
EST Kierra vuortellen
FIN Dra åt växelvis
S Aperte alternadamente
PT Apretar alternativamente
E Alternare il serraggio delle viti
I rechterkant aandraden
NL rechtszijdig aan de linker- en de
F Serretter abwechselnd
D Die Schrauben abwechselnd
anziehen
anziehen

CZ Pokrývka bagazníka dokrecaj
SK Dokrecaj napremitelno.
SLO Privajite izmenično.
HU Naizmjenično zategnite.
HR Egymástól fűggetlenül
szorítandó
GR Αφύτες εναλλάξ
TR Dönüşümlü sıkın
中文 交替拧紧
한국어 번갈아 가며 조이십시오.
日本語 交互に締め付けてください。
Українська Затримувати поперемінно

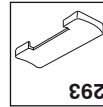
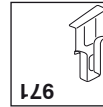
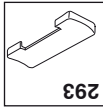
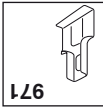
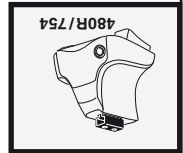
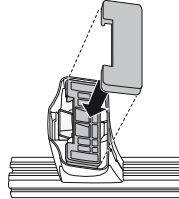
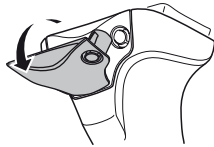
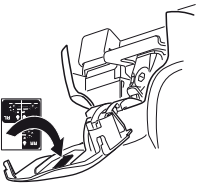
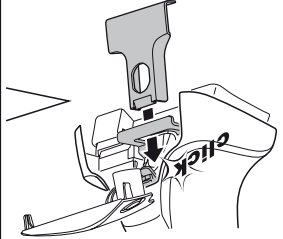
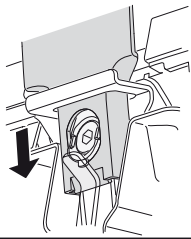
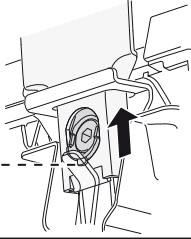
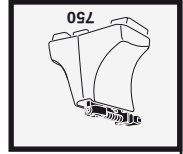
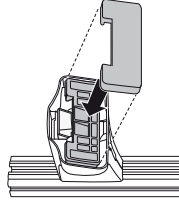
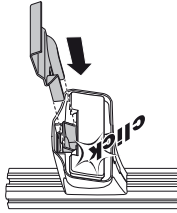
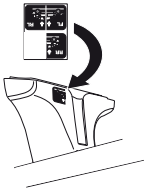

KIT 1475

KIT 1475

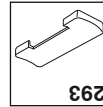
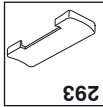
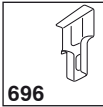
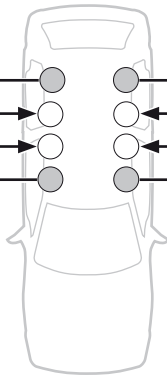

HYUNDAI H-1, 5-dr Van, 08-
HYUNDAI iLoad, 5-dr Van, 08-
HYUNDAI iMax, 5-dr Bus, 08-
HYUNDAI Starex, 5-dr Van, 08-

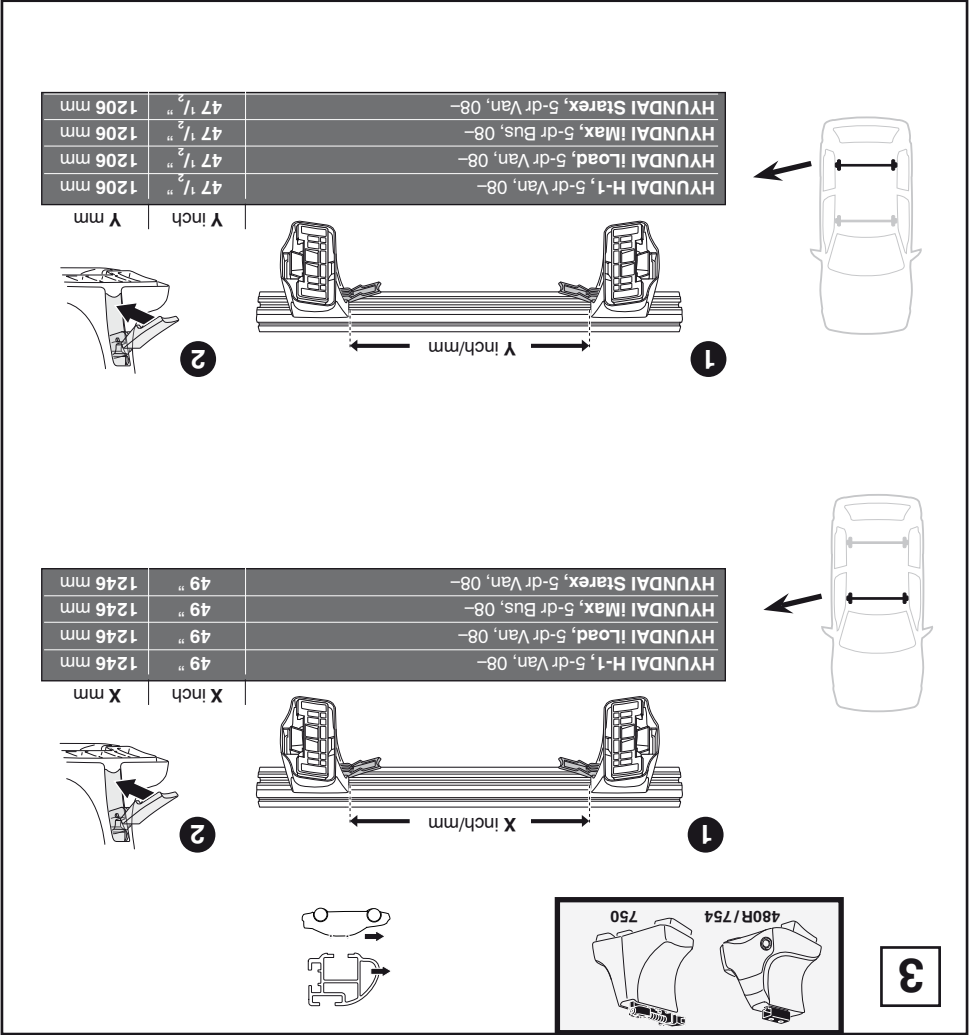
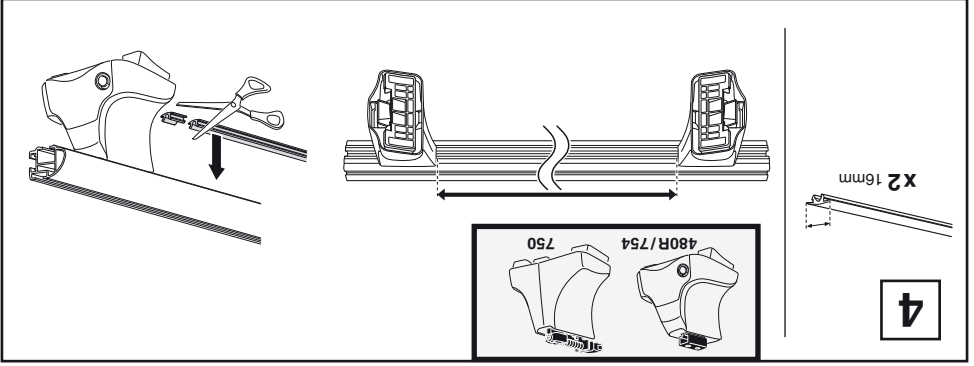

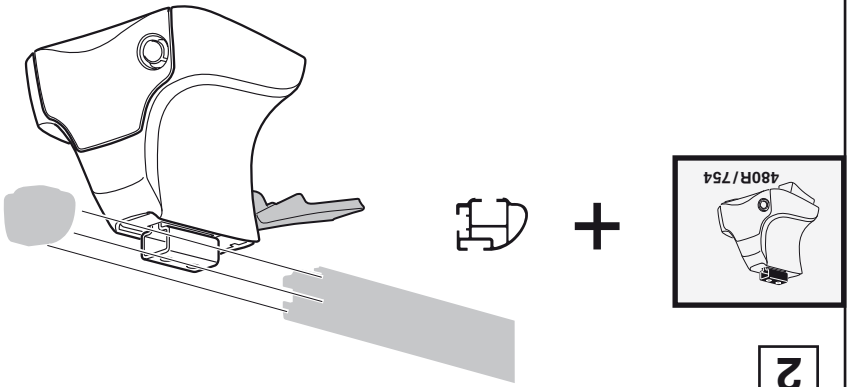
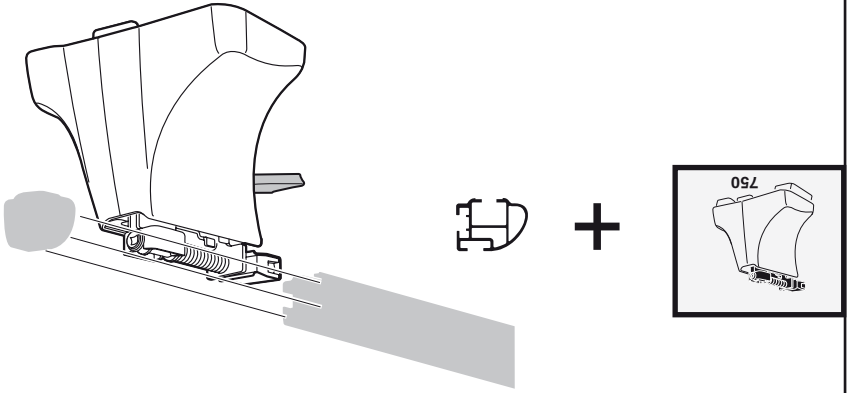

2

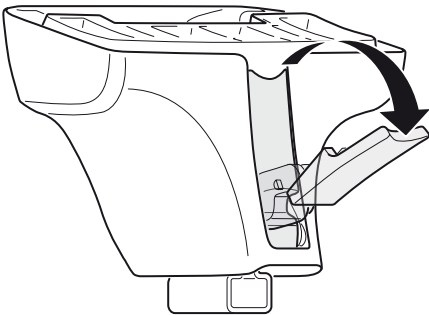

1

Kit

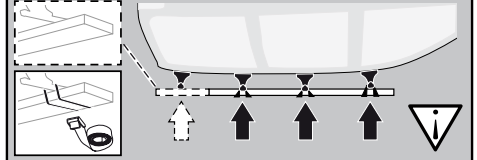
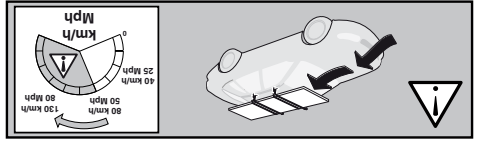
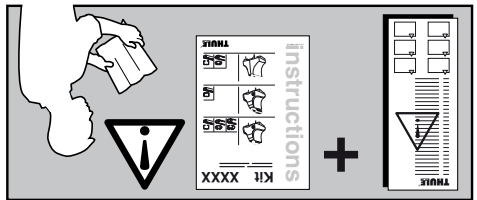
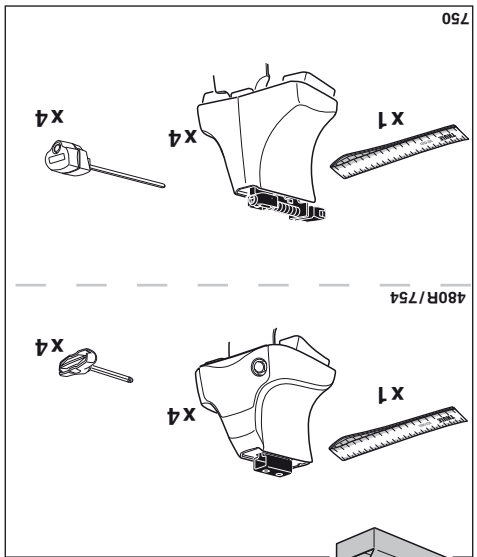
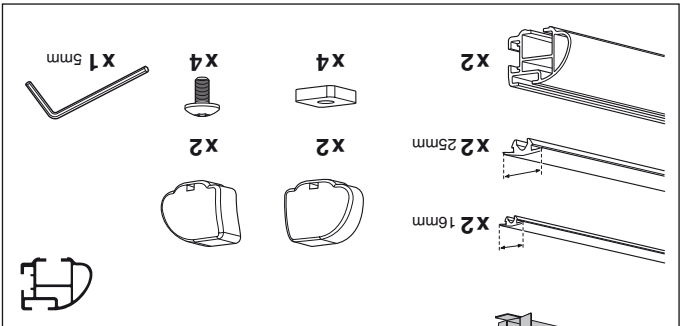
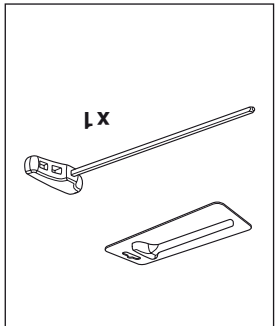
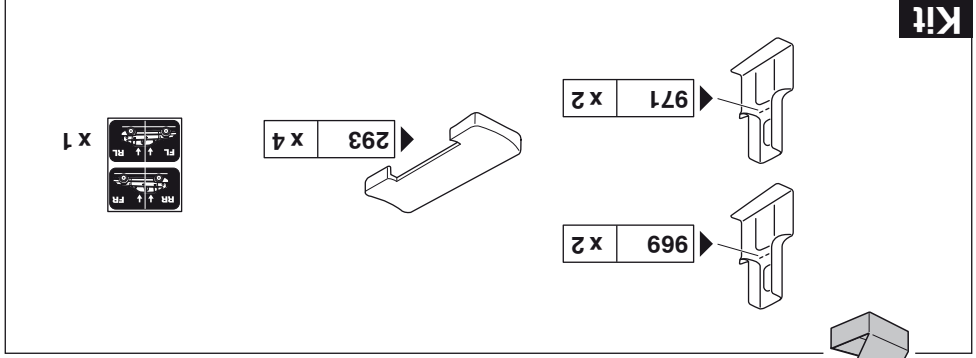

instructions

ISO 11154-E

PROFESSIONAL

THULE
SWEDEN®

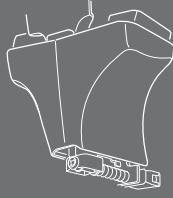

750

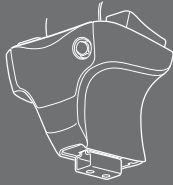
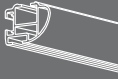

480R
754

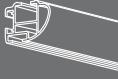

* with dual sliding doors
** with dual sliding doors (Asia)

HYUNDAI H-1, 5-dr Van, 08-*
HYUNDAI iLoad, 5-dr Van, 08-**
HYUNDAI iMax, 5-dr Bus, 08-**
HYUNDAI Starex, 5-dr Van, 08-*

Kit 1469